

UNIT – I

INTRODUCTION TO MEASURING INSTRUMENTS:

1. Definition of instruments

An instrument is a device in which we can determine the magnitude or value of the quantity to be measured. The measuring quantity can be voltage, current, power and energy etc. Generally instruments are classified in to two categories.

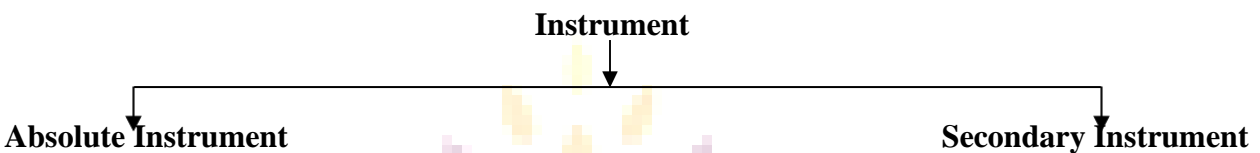

Absolute instrument

An absolute instrument determines the magnitude of the quantity to be measured in terms of the instrument parameter. This instrument is really used, because each time the value of the measuring quantities varies. So we have to calculate the magnitude of the measuring quantity, analytically which is time consuming. These types of instruments are suitable for laboratory use. Example: Tangent galvanometer.

Secondary instrument

This instrument determines the value of the quantity to be measured directly. Generally these instruments are calibrated by comparing with another standard secondary instrument.

Examples of such instruments are voltmeter, ammeter and wattmeter etc. Practically secondary instruments are suitable for measurement.

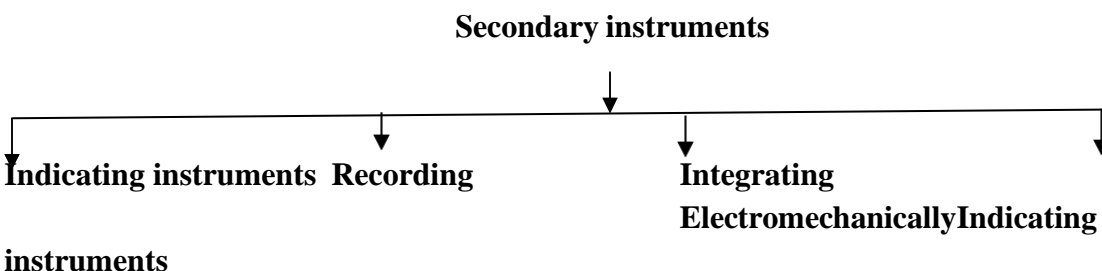

Electrical Measurements & Instrumentation (EE3101PC)

Indicating instrument

This instrument uses a dial and pointer to determine the value of measuring quantity. The pointer indication gives the magnitude of measuring quantity.

Recording instrument

This type of instruments records the magnitude of the quantity to be measured continuously over a specified period of time.

Integrating instrument

This type of instrument gives the total amount of the quantity to be measured over a specified period of time.

Electromechanical indicating instrument

For satisfactory operation electromechanical indicating instrument, three forces are necessary.

They are

- (a) Deflecting force
- (b) Controlling force
- (c) Damping force
- (d) **Deflecting force**

When there is no input signal to the instrument, the pointer will be at its zero position. To deflect the pointer from its zero position, a force is necessary which is known as deflecting force. A system which produces the deflecting force is known as a deflecting system. Generally a deflecting system converts an electrical signal to a mechanical force.

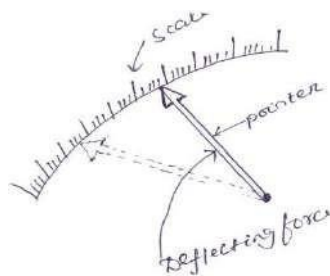

Fig. 1.1 Pointer scale

Magnitude effect

When a current passes through the coil (Fig.1.2), it produces an imaginary bar magnet. When a soft-iron piece is brought near this coil it is magnetized. Depending upon the current direction the poles are produced in such a way that there will be a force of attraction between the coil and the soft iron piece. This principle is used in moving iron attraction type instrument.

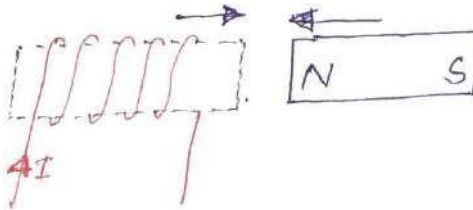

Fig. 1.2

If two soft iron pieces are placed near a current-carrying coil there will be a force of repulsion between the two soft iron pieces. This principle is utilized in the moving iron repulsion type instrument.

Force between a permanent magnet and a current-carrying coil

When a current-carrying coil is placed under the influence of a magnetic field produced by a permanent magnet, a force is produced between them. This principle is utilized in the moving coil type instrument.

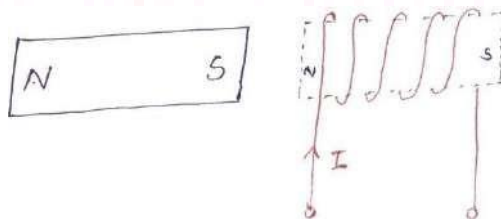

Fig. 1.3

Force between two current-carrying coils

When two current-carrying coils are placed closer to each other there will be a force of repulsion between them. If one coil is movable and the other is fixed, the movable coil will move away from the fixed one. This principle is utilized in electro-dynamometer type instrument.

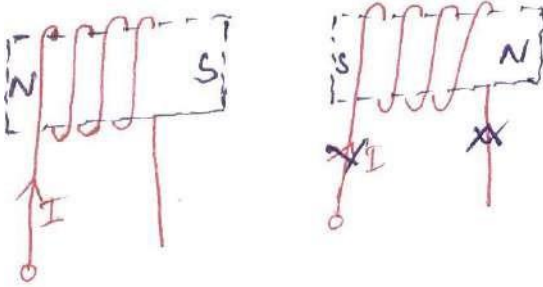

Fig. 1.4

Controlling force

To make the measurement indicated by the pointer definite (constant) a force is necessary which will be acting in the opposite direction to the deflecting force. This force is known as controlling force. A system which produces this force is known as a controlled system. When the external signal to be measured by the instrument is removed, the pointer should return back to the zero position. This is possibly due to the controlling force and the pointer will be indicating a steady value when the deflecting torque is equal to controlling torque.

$$T_d = T_c \quad (1.1)$$

Spring control

Two springs are attached on either end of spindle (Fig. 1.5). The spindle is placed in jewelled bearing, so that the frictional force between the pivot and spindle will be minimum. Two springs are provided in opposite direction to compensate the temperature error. The spring is made of phosphorous bronze.

When a current is supply, the pointer deflects due to rotation of the spindle. While spindle is rotate, the spring attached with the spindle will oppose the movements of the pointer. The torque produced by the spring is directly proportional to the pointer deflection θ .

$$T_C \propto \theta \quad (1.2)$$

The deflecting torque produced T_d proportional to 'I'. When $T_C = T_d$, the pointer will come to a steady position. Therefore

$$\theta \propto I \quad (1.3)$$

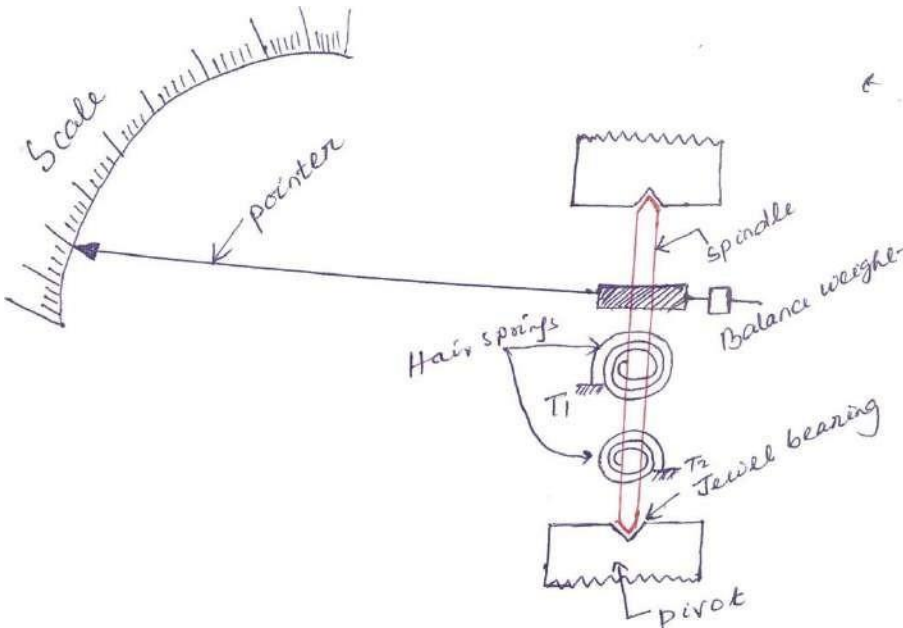

Fig. 1.5

Since, θ and I are directly proportional to the scale of such instrument which uses spring controlled is uniform.

Damping force

The deflection torque and controlling torque produced by systems are electro mechanical. Due to inertia produced by this system, the pointer oscillates about its final steady position before coming to rest. The time required to take the measurement is more. To damp out the oscillation as quickly as possible, a damping force is necessary. This force is produced by different systems.

- (a) Air friction damping
- (b) Fluid friction damping
- (c) Eddy current damping

Air friction damping

The piston is mechanically connected to a spindle through the connecting rod (Fig. 1.6). The pointer is fixed to the spindle. When the pointer oscillates in clockwise direction, the piston goes inside and the cylinder gets compressed. The air pushes the piston upwards and the pointer tends to move in anticlockwise direction.

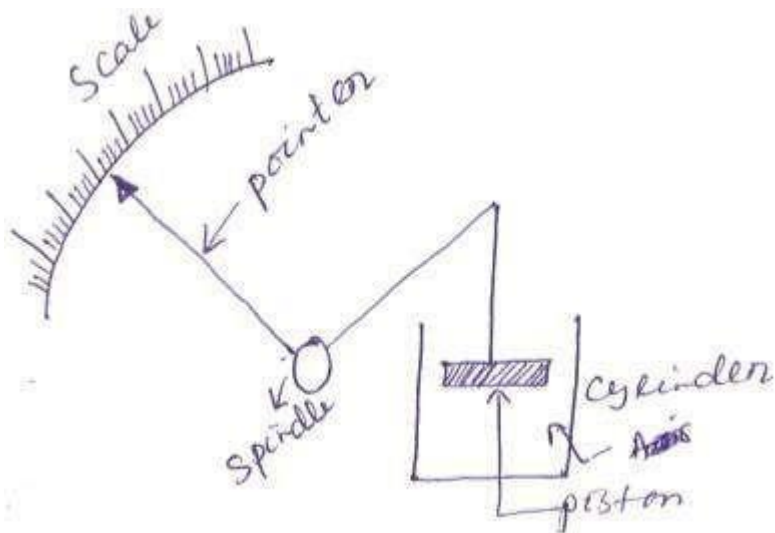

Fig. 1.6

If the pointer oscillates in anticlockwise direction the piston moves away and the pressure of the air inside cylinder gets reduced. The external pressure is more than that of the internal pressure. Therefore the piston moves down wards. The pointer tends to move in clock wise direction.

Eddy current damping

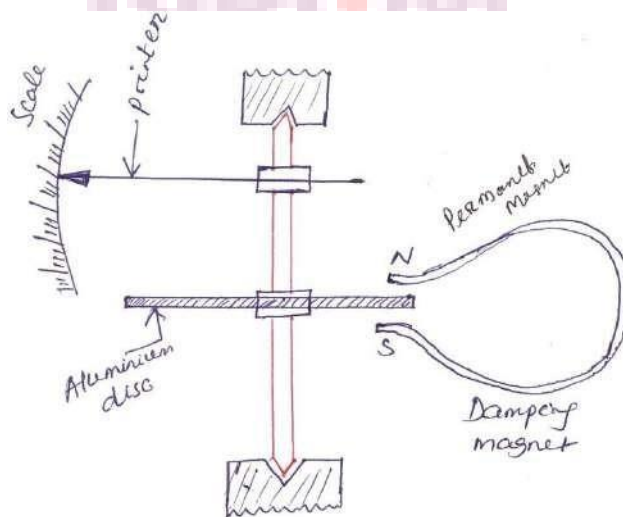

Fig. 1.6 Disc type

An aluminum circular disc is fixed to the spindle (Fig. 1.6). This disc is made to move in the magnetic field produced by a permanent magnet.

Electrical Measurements & Instrumentation (EE3101PC)

When the disc oscillates it cuts the magnetic flux produced by damping magnet. An emf is induced in the circular disc by Faraday's law. Eddy currents are established in the disc since it has several closed paths. By Lenz's law, the current carrying disc produces a force in a direction opposite to oscillating force. The damping force can be varied by varying the projection of the magnet over the circular disc.

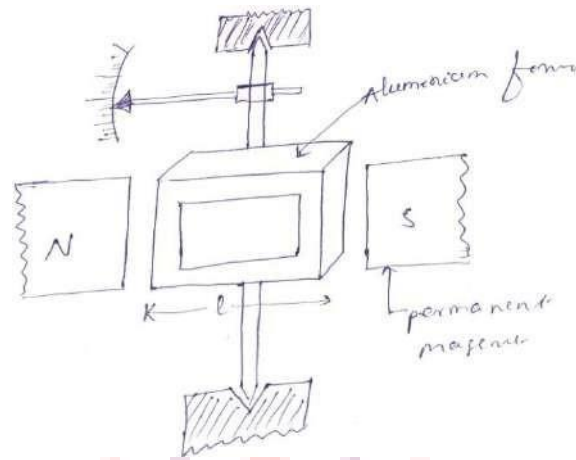

Fig. 1.6 Rectangular type

Permanent Magnet Moving Coil (PMMC) instrument

One of the most accurate type of instrument used for D.C. measurements is PMMC instrument. **Construction:** A permanent magnet is used in this type instrument. Aluminum former is provided in the cylindrical in between two poles of the permanent magnet (Fig. 1.7). Coils are wound on the aluminum former which is connected with the spindle. This spindle is supported with jeweled bearing. Two springs are attached on either end of the spindle. The terminals of the moving coils are connected to the spring. Therefore the current flows through spring 1, moving coil and spring 2.

Damping: Eddy current damping is used. This is produced by aluminum former.

Control: Spring control is used.

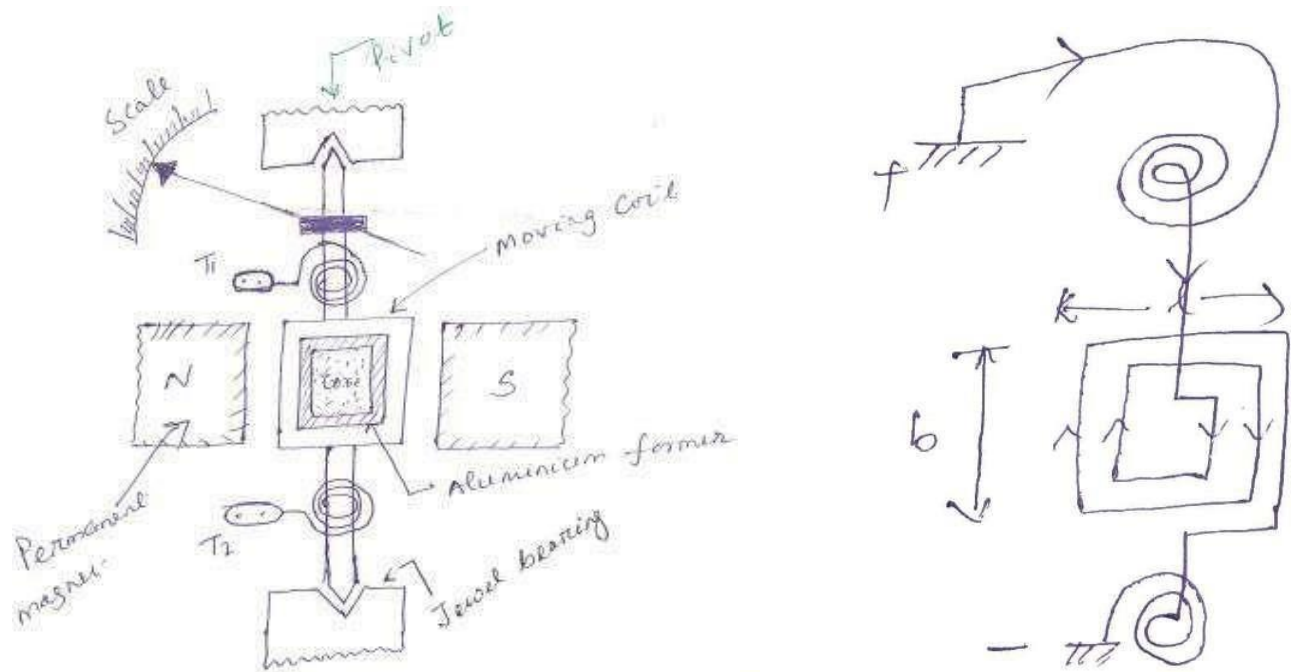

Fig. 1.7

Principle of operation

When D.C. supply is given to the moving coil, D.C. current flows through it. When the current carrying coil is kept in the magnetic field, it experiences a force. This force produces a torque and the former rotates. The pointer is attached with the spindle. When the former rotates, the pointer moves over the calibrated scale. When the polarity is reversed a torque is produced in the opposite direction. The mechanical stopper does not allow the deflection in the opposite direction. Therefore the polarity should be maintained with PMMC instrument. If A.C. is supplied, a reversing torque is produced. This cannot produce a continuous deflection. Therefore this instrument cannot be used in A.C.

Torque developed by PMMC

Let T_d = deflecting torque

T_C = controlling torque

θ = angle of deflection

K = spring constant b = width
of the coil

Electrical Measurements & Instrumentation (EE3101PC)

l =height of the coil or length of coil N =No. of turns

I =current B =Flux density A =area of the coil

The force produced in the coil is given by

$$F = BIL \sin\theta$$

When $\theta=90^\circ$ (1.4)

For N turns, $F = NBIL$ (1.5)

Torque produced $T_d = F \times \perp_r$ distance (1.6)

$$T_d = NBIL \times b = BINA$$
 (1.7)

$$T_d = BANl$$
 (1.8)

$$T_d \propto I$$
 (1.9)

Advantages

- ✓ Torque/weight is high
- ✓ Power consumption is less
- ✓ Scale is uniform
- ✓ Damping is very effective
- ✓ Since operating field is very strong, the effect of stray field is negligible
- ✓ Range of instrument can be extended

Disadvantages

- ✓ Use only for D.C.
- ✓ Cost is high
- ✓ Error is produced due to ageing effect of PMMC
- ✓ Friction and temperature error are present

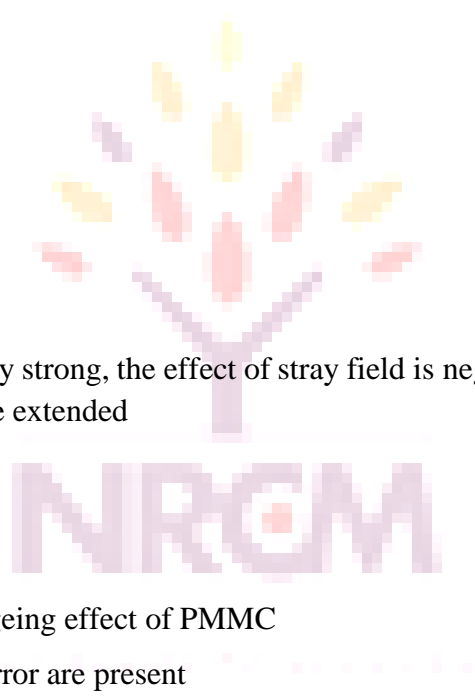

Electrical Measurements & Instrumentation (EE3101PC)

| 1 + $R \rightarrow$ Multiplication facto

Moving Iron (MI) instruments

One of the most accurate instrument used for both AC and DC measurement is moving iron instrument. There are two types of moving iron instrument.

- Attraction type
- Repulsion type

Attraction type M.I. instrument

Construction: The moving iron fixed to the spindle is kept near the hollow fixed coil (Fig. 1.10). The pointer and balance weight are attached to the spindle, which is supported with jeweled bearing. Here air friction damping is used.

Principle of operation

The current to be measured is passed through the fixed coil. As the current is flow through the fixed coil, a magnetic field is produced. By magnetic induction the moving iron gets magnetized. The north pole of moving coil is attracted by the south pole of fixed coil. Thus the deflecting force is produced due to force of attraction. Since the moving iron is attached with the spindle, the spindle rotates and the pointer moves over the calibrated scale. But the force of attraction depends on the current flowing through the coil.

Torque developed by M.I

Let ' θ ' be the deflection corresponding to a current of ' i ' amp

Let the current increases by di , the corresponding deflection is ' $\theta+d\theta$ '

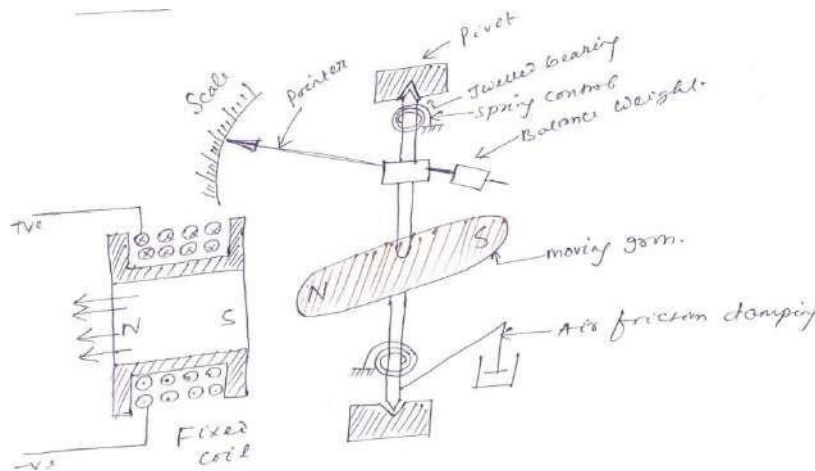

Electrical Measurements & Instrumentation (EE3101PC)

Fig. 1.10

There is change in inductance since the position of moving iron change w.r.t the fixed electromagnets.

Let the new inductance value be ' $L+dL$ '. The current change by ' di ' is dt seconds.

Let the emf induced in the coil be ' e ' volt.

$$e = \frac{d}{dt}(Li) = L \frac{di}{dt} + i \frac{dL}{dt} \quad (1.22)$$

Multiplying by ' idt ' in equation (1.22)

$$e \times idt = L \frac{di}{dt} \times idt + i \frac{dL}{dt} \times idt \quad (1.23)$$

$$e \times idt = Lidi + i^2 dL \quad (1.24)$$

Eqⁿ (1.24) gives the energy is used in to two forms. Part of energy is stored in the inductance. Remaining energy is converted in to mechanical energy which produces deflection.



Fig. 1.11

Electrical Measurements & Instrumentation (EE3101PC)

Change in energy stored=Final energy-initial energy stored

$$\begin{aligned}
 &= \frac{1}{2}(L + dL)(i + di)^2 - \frac{1}{2}Li^2 \\
 &= \frac{1}{2}\{(L + dL)(i^2 + di^2 + 2idi) - Li^2\} \\
 &= \frac{1}{2}\{(L + dL)(i^2 + 2idi) - Li^2\} \\
 &= \frac{1}{2}\{Li^2 + 2Lidi + i^2dL + 2ididL - Li^2\} \\
 &= \frac{1}{2}\{2Lidi + i^2dL\} \\
 &= Lidi + \frac{1}{2}i^2dL \tag{1.25}
 \end{aligned}$$

Mechanical work to move the pointer by $d\theta$

$$= T_d d\theta \tag{1.26}$$

By law of conservation of energy,

Electrical energy supplied=Increase in stored energy+ mechanical work done.

Input energy= Energy stored + Mechanical energy

$$Lidi + i^2dL = Lidi + \frac{1}{2}i^2dL + T_d d\theta \tag{1.27}$$

$$\frac{1}{2}i^2dL = T_d d\theta \tag{1.28}$$

$$T_d = \frac{1}{2}i^2 \frac{dL}{d\theta} \tag{1.29}$$

At steady state condition $T_d = T_C$

$$\frac{1}{2}i^2 \frac{dL}{d\theta} = K\theta \tag{1.30}$$

$$\theta = \frac{1}{2K}i^2 \frac{dL}{d\theta} \tag{1.31}$$

$$\theta \propto i^2 \tag{1.32}$$

When the instruments measure AC, $\theta \propto i_{rms}^2$

Electrical Measurements & Instrumentation (EE3101PC)

Advantages

- ✓ MI can be used in AC and DC
- ✓ It is cheap
- ✓ Supply is given to a fixed coil, not in moving coil.
- ✓ Simple construction
- ✓ Less friction error.

Disadvantages

- ✓ It suffers from eddy current and hysteresis error
- ✓ Scale is not uniform
- ✓ It consumed more power
- ✓ Calibration is different for AC and DC operation

Repulsion type moving iron instrument

Construction: The repulsion type instrument has a hollow fixed iron attached to it (Fig. 1.12). The moving iron is connected to the spindle. The pointer is also attached to the spindle in supported with jeweled bearing.

Principle of operation: When the current flows through the coil, a magnetic field is produced by it. So both fixed iron and moving iron are magnetized with the same polarity, since they are kept in the same magnetic field. Similar poles of fixed and moving iron get repelled. Thus the deflecting torque is produced due to magnetic repulsion. Since moving iron is attached to spindle, the spindle will move. So that pointer moves over the calibrated scale.

Damping: Air friction damping is used to reduce the oscillation. Control: Spring control is used.

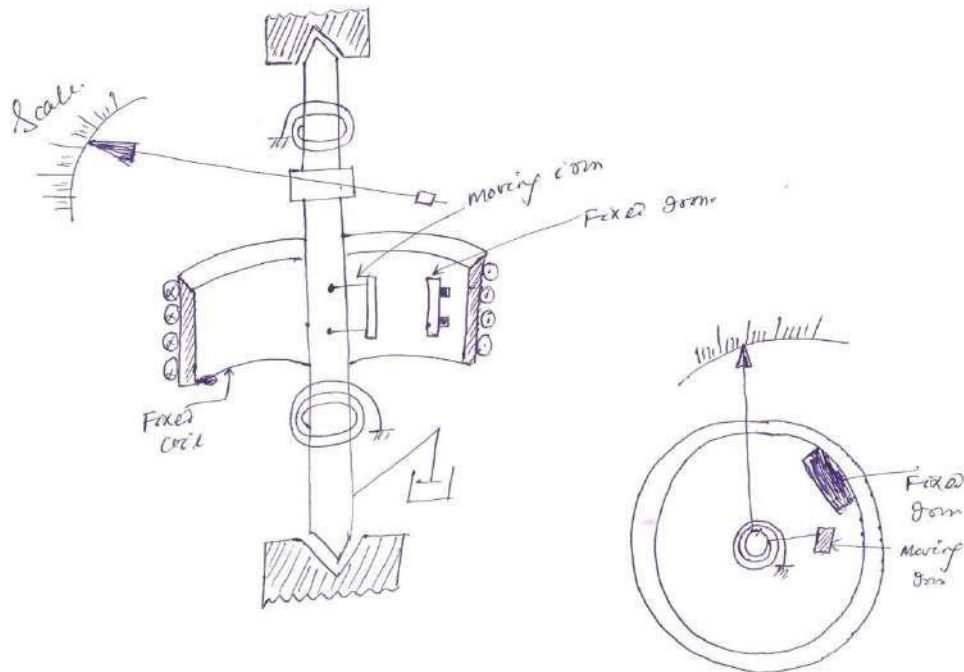

Fig. 1.12

Dynamometer (or) Electromagnetic moving coil instrument(EMMC)

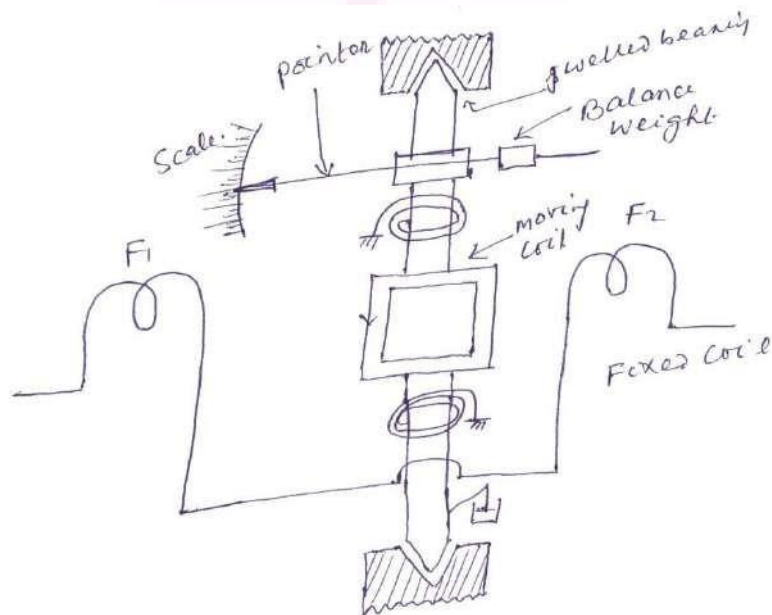

Fig. 1.13

Electrical Measurements & Instrumentation (EE3101PC)

This instrument can be used for the measurement of voltage, current and power. The difference between the PMMC and dynamometer type instrument is that the permanent magnet is replaced by an electromagnet.

Construction: A fixed coil is divided into two equal halves. The moving coil is placed between the two halves of the fixed coil. Both the fixed and moving coils are air cored. So that the hysteresis effect will be zero. The pointer is attached with the spindle. In a non-metallic former the moving coil is wound.

Control: Spring control is used.

Damping: Air friction damping is

used. **Principle of operation:**

When the current flows through the fixed coil, it produces a magnetic field, whose flux density is proportional to the current through the fixed coil. The moving coil is kept in between the fixed coil. When the current passes through the moving coil, a magnetic field is produced by this coil.

The magnetic poles are produced in such a way that the torque produced on the moving coil deflects the pointer over the calibrated scale. This instrument works on AC and DC. When AC voltage is applied, alternating current flows through the fixed coil and moving coil. When the current in the fixed coil reverses, the current in the moving coil also reverses. Torque remains in the same direction. Since the current i_1 and i_2 reverse simultaneously. This is because the fixed and moving coils are either connected in series or parallel.

Torque developed by EMMC

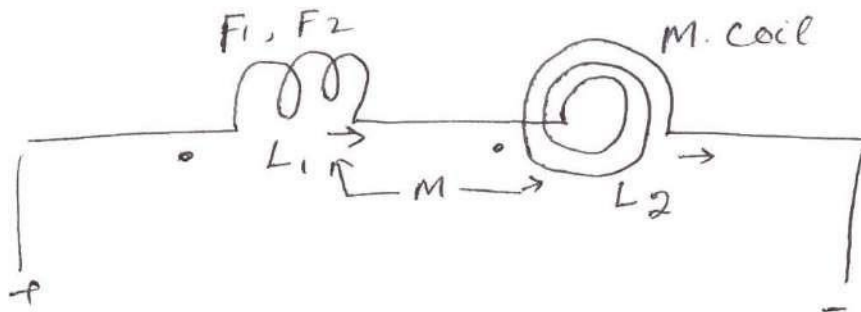

Fig. 1.14

Let

Electrical Measurements & Instrumentation (EE3101PC)

L_1 =Self inductance of fixed coil

L_2 =Self inductance of moving coil

M =mutual inductance between fixed coil and moving coil i_1 =current through fixed coil

i_2 =current through moving coil Total inductance of system,

$$L_{total} = L_1 + L_2 + 2M \quad (1.33)$$

But we know that in case of M.I

$$T_d = \frac{1}{2} i^2 \frac{d(L)}{d\theta} \quad (1.34)$$

$$T_d = \frac{1}{2} i^2 \frac{d}{d\theta} (L_1 + L_2 + 2M) \quad (1.35)$$

The value of L_1 and L_2 are independent of ' θ ' but ' M ' varies with θ

$$T_d = \frac{1}{2} i^2 \times 2 \frac{dM}{d\theta} \quad (1.36)$$

$$T_d = i^2 \frac{dM}{d\theta} \quad (1.37)$$

If the coils are not connected in series $i_1 \neq i_2$

$$\therefore T_d = i_1 i_2 \frac{dM}{d\theta} \quad (1.38)$$

$$T_C = T_d \quad (1.39)$$

$$\therefore \theta = \frac{i_1 i_2}{K} \frac{dM}{d\theta} \quad (1.40)$$

Hence the deflection of pointer is proportional to the current passing through fixed coil and moving coil.

Electrical Measurements & Instrumentation (EE3101PC)

Extension of PMMC instrument

Case-I Ammeter connection

Fixed coil and moving coil are connected in parallel for ammeter connection. The coils are redesigned such that the resistance of each branch is same.

Therefore

$$I_1 = I_2 = I$$

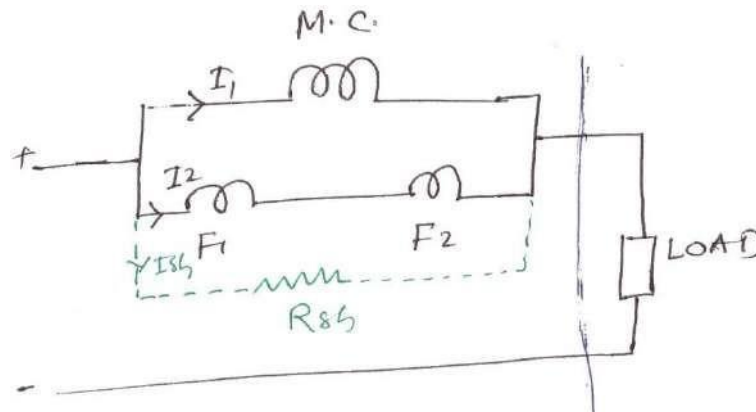

Fig. 1.15

To extend the range of current a shunt may be connected in parallel with the meter. The value R_{sh} is designed such that equal current flows through moving coil and fixed coil.

$$\therefore T_d = I_1 I_2 \frac{dM}{d\theta} \quad (1.41)$$

$$\text{Or } \therefore T_d = I^2 \frac{dM}{d\theta} \quad (1.42)$$

$$T_C = K\theta \quad (1.43)$$

$$\theta = \frac{I^2}{K} \frac{dM}{d\theta} \quad (1.44)$$

$$\therefore \theta \propto I^2 \text{ (Scale is not uniform)} \quad (1.45)$$

Case-II Voltmeter connection

Fixed coil and moving coil are connected in series for voltmeter connection. A multiplier may be connected in series to extend the range of voltmeter.

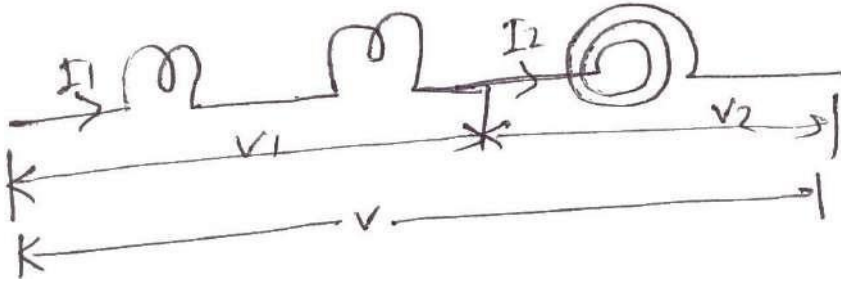

$$I_1 = \frac{V_1}{Z_1}, I_2 = \frac{V_2}{Z_2} \quad (1.46)$$

$$T_d = \frac{V_1}{Z_1} \times \frac{V_2}{Z_2} \times \frac{dM}{d\theta} \quad (1.47)$$

$$T_d = \frac{K_1 V}{Z_1} \times \frac{K_2 V}{Z_2} \times \frac{dM}{d\theta} \quad (1.48)$$

$$T_d = \frac{KV^2}{Z_1 Z_2} \times \frac{dM}{d\theta} \quad (1.49)$$

$$T_d \propto V^2 \quad (1.50)$$

$$\therefore \theta \propto V^2 \quad (\text{Scale is not uniform}) \quad (1.51)$$



Case-III As wattmeter

When the two coils are connected to parallel, the instrument can be used as a wattmeter. Fixed coil is connected in series with the load. Moving coil is connected in parallel with the load. The moving coil is known as voltage coil or pressure coil and fixed coil is known as current coil.

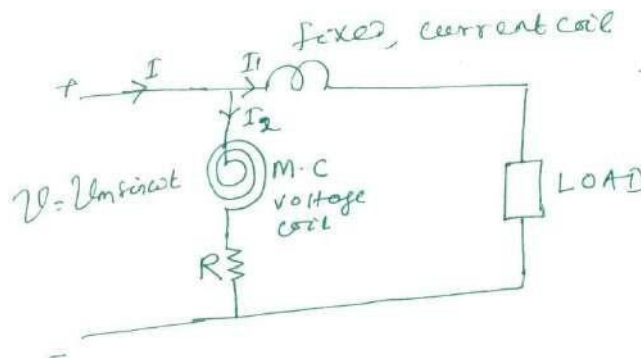

Fig. 1.17

Electrical Measurements & Instrumentation (EE3101PC)

Assume that the supply voltage is sinusoidal. If the impedance of the coil is neglected in comparison with the resistance 'R'. The current,

$$I_2 = \frac{v_m \sin wt}{R}$$

Let the phase difference between the currents I_1 and I_2 is ϕ

$$I_1 = I_m \sin(wt - \phi)$$

$$T_d = I_1 I_2 \frac{dM}{d\theta}$$

$$T_d = I_m \sin(wt - \phi) \times \frac{V_m \sin wt}{R} \frac{dM}{d\theta}$$

$$T_d = \frac{1}{R} (I_m V_m \sin wt \sin(wt - \phi)) \frac{dM}{d\theta}$$

$$T_d = \frac{1}{R} I_m V_m \sin wt \cdot \sin(wt - \phi) \frac{dM}{d\theta}$$

The average deflecting torque

$$(T_d)_{avg} = \frac{1}{2\pi} \int_0^{2\pi} T_d \times d(wt) \quad (1.58)$$

$$(T_d)_{avg} = \frac{1}{2\pi} \int_0^{2\pi} \frac{1}{R} \times I_m V_m \sin wt \cdot \sin(wt - \phi) \frac{dM}{d\theta} \times d(wt) \quad (1.59)$$

$$(T_d)_{avg} = \frac{V_m I_m}{2 \times 2\pi} \times \frac{1}{R} \times \frac{dM}{d\theta} \left[\int \{ \cos \phi - \cos(2wt - \phi) \} dwt \right] \quad (1.60)$$

$$(T_d)_{avg} = \frac{V_m I_m}{4\pi R} \times \frac{dM}{d\theta} \left[\int_0^{2\pi} \cos \phi \cdot dwt - \int_0^{2\pi} \cos(2wt - \phi) \cdot dwt \right] \quad (1.61)$$

$$(T_d)_{avg} = \frac{V_m I_m}{4\pi R} \times \frac{dM}{d\theta} \left[\cos \phi [wt]_0^{2\pi} \right] \quad (1.62)$$

$$(T_d)_{avg} = \frac{V_m I_m}{4\pi R} \times \frac{dM}{d\theta} \left[\cos \phi (2\pi - 0) \right] \quad (1.63)$$

$$(T_d)_{avg} = \frac{V_m I_m}{2} \times \frac{1}{R} \times \frac{dM}{d\theta} \times \cos \phi \quad (1.64)$$

$$(T_d)_{avg} = V_{rms} \times I_{rms} \times \cos \phi \times \frac{1}{R} \times \frac{dM}{d\theta} \quad (1.65)$$

Electrical Measurements & Instrumentation (EE3101PC)

$$(T_d)_{avg} \propto KVI \cos \phi$$

$$T_C \propto \theta$$

$$\theta \propto KVI \cos \phi$$

$$\theta \propto VI \cos \phi$$

Advantages

- ✓ It can be used for voltmeter, ammeter and wattmeter
- ✓ Hysteresis error is nill
- ✓ Eddy current error is nill
- ✓ Damping is effective
- ✓ It can be measure correctively and accurately the rms value of the voltage

Disadvantages

- ✓ Scale is not uniform
- ✓ Power consumption is high(because of high resistance)
- ✓ Cost is more
- ✓ Error is produced due to frequency, temperature and stray field.
- ✓ Torque/weight is low.(Because field strength is very low)

Errors in PMMC

- ✓ The permanent magnet produced error due to ageing effect. By heat treatment, this error can be eliminated.
- ✓ The spring produces error due to ageing effect. By heat treating the spring the error can be eliminated.
- ✓ When the temperature changes, the resistance of the coil vary and the spring also produces error in deflection. This error can be minimized by using a spring whose temperature coefficient is very low.

Difference between attraction and repulsion type instrument

An attraction type instrument will usually have a lower inductance, compare to repulsion type instrument. But in other hand, repulsion type instruments are more suitable for economical production in manufacture and nearly uniform scale is more easily obtained. They are therefore much more common than attraction type.

Electrical Measurements & Instrumentation (EE3101PC)

Characteristics of meter

Full scale deflection current(I_{FSD})

The current required to bring the pointer to full-scale or extreme right side of the instrument is called full scale deflection current. It must be as small as possible. Typical value is between 2 μ A to 30mA.

Resistance of the coil(R_m)

This is ohmic resistance of the moving coil. It is due to ρ , L and A. For an ammeter this should be as small as possible.

Sensitivity of the meter(S)

$$S = \frac{1}{I_{FSD}} (\Omega/volt), \uparrow S = \frac{Z \uparrow}{V}$$

It is also called ohms/volt rating of the instrument. Larger the sensitivity of an instrument, more accurate is the instrument. It is measured in $\Omega/volt$. When the sensitivity is high, the impedance of meter is high. Hence it draws less current and loading effect is negligible. It also depends as one over full scale deflection current.

Error in M.I instrument

Temperature error

Due to temperature variation, the resistance of the coil varies. This affects the deflection of the instrument. The coil should be made of manganin, so that the resistance is almost constant.

Hysteresis error

Due to hysteresis effect the reading of the instrument will not be correct. When the current is decreasing, the flux produced will not decrease suddenly. Due to this the meter reads a higher value of current. Similarly when the current increases the meter reads a lower value of current. This produces error in deflection. This error can be eliminated using small iron parts with narrow hysteresis loop so that the demagnetization takes place very quickly.

Eddy current error

The eddy currents induced in the moving iron affect the deflection. This error can be reduced by increasing the resistance of the iron.

Electrical Measurements & Instrumentation (EE3101PC)

Stray field error

Since the operating field is weak, the effect of stray field is more. Due to this, error is produced in deflection. This can be eliminated by shielding the parts of the instrument.

Frequency error

When the frequency changes the reactance of the coil changes.

$$Z = \sqrt{(R_m + R_S)^2 + X^2 L} \quad (1.70)$$

$$I = \frac{V}{Z} = \frac{V}{\sqrt{(R_m + R_S)^2 + X^2 L}} \quad (1.71)$$

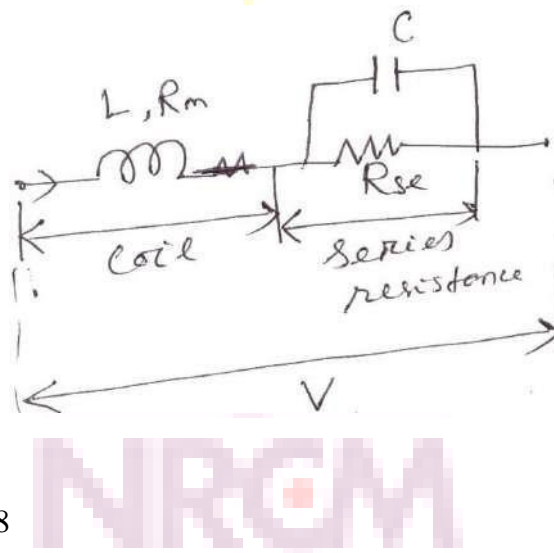

Fig. 1.18

Deflection of moving iron voltmeter depends upon the current through the coil. Therefore, deflection for a given voltage will be less at higher frequency than at low frequency. A capacitor is connected in parallel with multiplier resistance. The net reactance, $(X_L - X_C)$ is very small, when compared to the series resistance. Thus the circuit impedance is made independent of frequency. This is because of the circuit is almost resistive.

$$C = 0.41 \frac{L}{(R_S)^2} \quad (1.72)$$

Electrostatic instrument

In multi cellular construction several vanes and quadrants are provided. The voltage to be measured is applied between the vanes and quadrant. The force of attraction between the vanes

Electrical Measurements & Instrumentation (EE3101PC)

and quadrant produces a deflecting torque. Controlling torque is produced by spring control. Air friction damping is used.

The instrument is generally used for measuring medium and high voltage. The voltage is reduced to low value by using capacitor potential divider. The force of attraction is proportional to the square of the voltage.

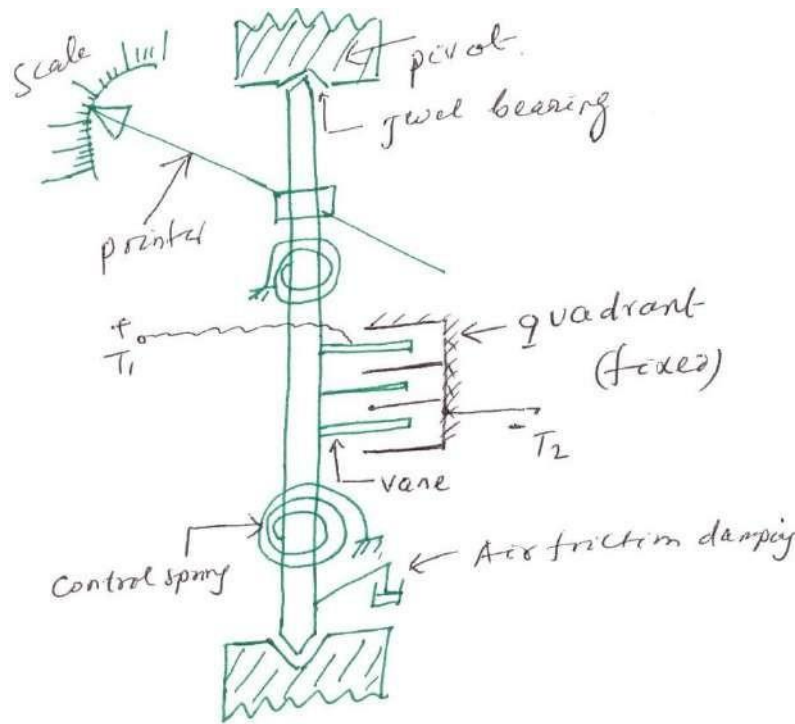
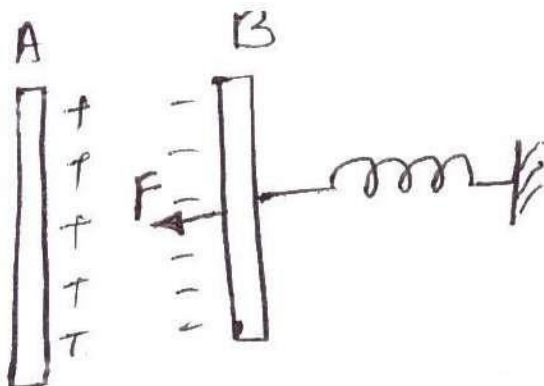

Fig. 1.19

Torque develop by electrostatic instrument

V = Voltage applied between vane and quadrant

C = capacitance between vane and quadrant



Electrical Measurements & Instrumentation (EE3101PC)

Fig. 1.20

$$Vidt = \frac{dC}{dt}V^2dt + CV \frac{dV}{dt}dt \quad (1.75)$$

$$Vidt = V^2dC + CVdV \quad (1.76)$$

$$\text{Change in stored energy} = \frac{1}{2}(C + dC)(V + dV)^2 - \frac{1}{2}CV^2 \quad (1.77)$$

$$\begin{aligned} &= \frac{1}{2}[(C + dC)V^2 + dV^2 + 2VdV] - \frac{1}{2}CV^2 \\ &= \frac{1}{2}[CV^2 + CdV^2 + 2CVdV + V^2dC + dCdV^2 + 2VdVdC] - \frac{1}{2}CV^2 \\ &= \frac{1}{2}V^2dC + CVdV \end{aligned}$$

$$V^2dC + CVdV = \frac{1}{2}V^2dC + CVdV + F \times rd\theta \quad (1.78)$$

$$T_d \times d\theta = \frac{1}{2}V^2dC \quad (1.79)$$

$$T_d = \frac{1}{2}V^2 \left(\frac{dC}{d\theta} \right) \quad (1.80)$$

At steady state condition, $T_d = T_C$

$$K\theta = \frac{1}{2}V^2 \left(\frac{dC}{d\theta} \right) \quad (1.81)$$

$$\theta = \frac{1}{2K}V^2 \left(\frac{dC}{d\theta} \right) \quad (1.82)$$

Advantages

- ✓ It is used in both AC and DC.
- ✓ There is no frequency error.
- ✓ There is no hysteresis error.
- ✓ There is no stray magnetic field error. Because the instrument works on electrostatic principle.
- ✓ It is used for high voltage

Electrical Measurements & Instrumentation (EE3101PC)

- ✓ Power consumption is negligible.

Disadvantages

- ✓ Scale is not uniform
- ✓ Large in size
- ✓ Cost is more

Multi range Ammeter

When the switch is connected to position (1), the supplied current I_1

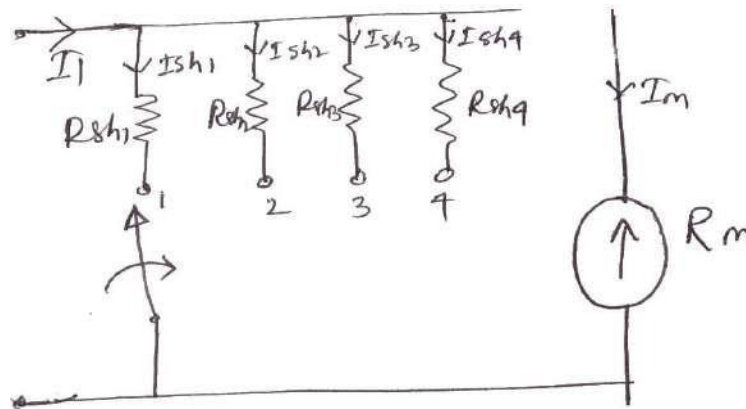

Fig. 1.21

$$I_{sh1}R_{sh1} = I_m R_m \quad (1.83)$$

$$R_{sh1} = \frac{I_m R_m}{I_{sh1}} = \frac{I_m R_m}{I_1 - I_m} \quad (1.84)$$

Electrical Measurements & Instrumentation (EE3101PC)

$$R_{sh1} = \frac{R_m}{\frac{I_1}{I_m} - 1}, R_{sh1} = \frac{R_m}{m_1 - 1}, m_1 = \frac{I_1}{I_m} = \text{Multiplying power of shunt}$$

$$R_{sh2} = \frac{R_m}{m_2 - 1}, m_2 = \frac{I_2}{I_m} \tag{1.85}$$

$$R_{sh3} = \frac{R_m}{m_3 - 1}, m_3 = \frac{I_3}{I_m} \tag{1.86}$$

$$R_{sh4} = \frac{R_m}{m_4 - 1}, m_4 = \frac{I_4}{I_m} \tag{1.87}$$

1.15 Ayrton shunt

$$R_1 = R_{sh1} - R_{sh2} \tag{1.88}$$

$$R_2 = R_{sh2} - R_{sh3} \tag{1.89}$$

$$R_3 = R_{sh3} - R_{sh4} \tag{1.90}$$

$$R_4 = R_{sh4} \tag{1.91}$$

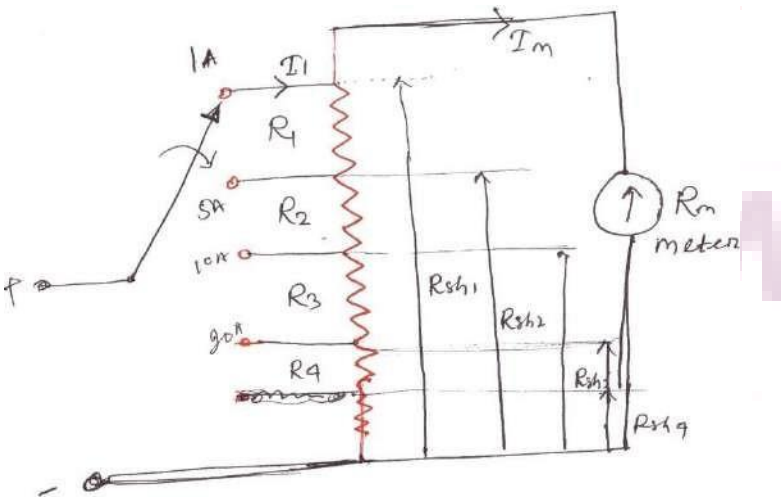
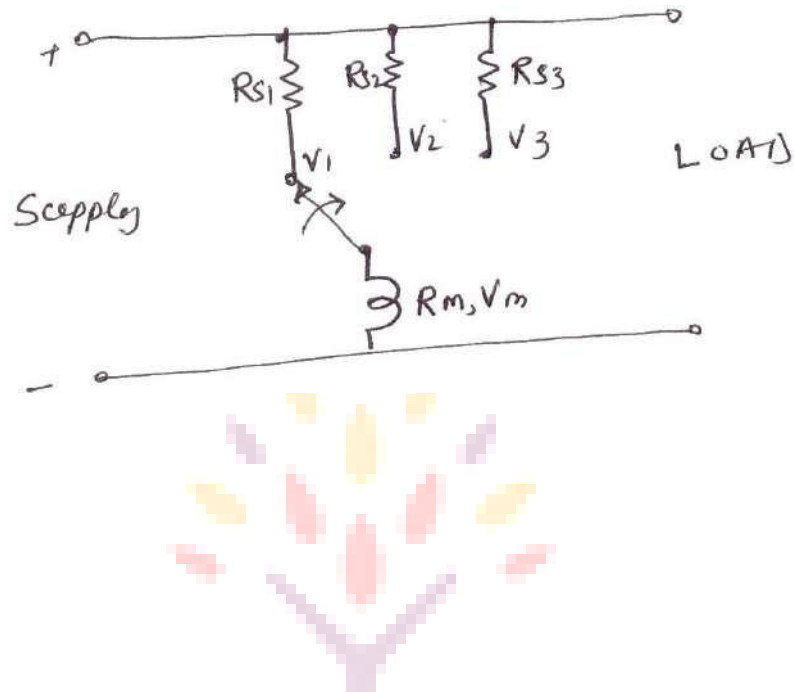

Fig. 1.22

Ayrton shunt is also called universal shunt. Ayrton shunt has more sections of resistance. Taps are brought out from various points of the resistor. The variable points in the o/p can be connected to any position. Various meters require different types of shunts. The Ayrton shunt is used in the lab, so that any value of resistance between minimum and maximum specified can be used. It eliminates the possibility of having the meter in the circuit without a shunt.

Electrical Measurements & Instrumentation (EE3101PC)

Multi range D.C.voltmeter



$$R_{s1} = R_m (m_1 - 1)$$

$$R_{s2} = R_m (m_2 - 1)$$

$$R_{s3} = R_m (m_3 - 1)$$

$$m_1 = \frac{V_1}{V_m}, m_2 = \frac{V_2}{V_m}, m_3 = \frac{V_3}{V_m}$$

Electrical Measurements & Instrumentation (EE3101PC)

Consider for voltage V_1 , $(R_1 + R_m)I_m = V_1$

$$\therefore R_1 = \frac{V_1}{I_m} - R_m = \frac{V_1}{\left(\frac{V_m}{R_m}\right)} - R_m = \left(\frac{V_1}{V_m}\right)R_m - R_m$$

$$R_1 = (m_1 - 1)R_m$$

For V_2 , $(R_2 + R_1 + R_m)I_m = V_2 \Rightarrow R_2 = \frac{V_2}{I_m} - R_1 - R_m$

$$R_2 = \frac{V_2}{\left(\frac{V_m}{R_m}\right)} - (m_1 - 1)R_m - R_m$$

$$\begin{aligned} R_2 &= m_2 R_m - R_m - (m_1 - 1)R_m \\ &= R_m(m_2 - 1 - m_1 + 1) \end{aligned}$$

$$R_2 = (m_2 - m_1)R_m$$

For V_3 $(R_3 + R_2 + R_1 + R_m)I_m = V_3$

$$R_3 = \frac{V_3}{I_m} - R_2 - R_1 - R_m$$

$$= \frac{V_3}{V_m} R_m - (m_2 - m_1)R_m - (m_1 - 1)R_m - R_m$$

$$= m_3 R_m - (m_2 - m_1)R_m - (m_1 - 1)R_m - R_m$$

$$R_3 = (m_3 - m_2)R_m$$

For V_4 $(R_4 + R_3 + R_2 + R_1 + R_m)I_m = V_4$

$$R_4 = \frac{V_4}{I_m} - R_3 - R_2 - R_1 - R_m$$

$$= \left(\frac{V_4}{V_m}\right)R_m - (m_3 - m_2)R_m - (m_2 - m_1)R_m - (m_1 - 1)R_m - R_m$$

$$R_4 = R_m[m_4 - m_3 + m_2 - m_2 + m_1 - m_1 + 1 - 1]$$

$$R_4 = (m_4 - m_3)R_m$$

Electrical Measurements & Instrumentation (EE3101PC)

We can obtain different Voltage ranges by connecting different value of multiplier resistor in series with the meter. The number of these resistors is equal to the number of ranges required.

Potential divider arrangement

The resistance R_1, R_2, R_3 and R_4 is connected in series to obtained the ranges V_1, V_2, V_3 and V_4

Example: 1.1

A PMMC ammeter has the following specification

Coil dimension are $1\text{cm} \times 1\text{cm}$. Spring constant is $0.15 \times 10^{-6} \text{ N-m/rad}$, Flux density is $1.5 \times 10^{-3} \text{ wb/m}^2$. Determine the no. of turns required to produce a deflection of 90° when a current 2mA flows through the coil.

Solution:

Solution:

At steady state condition $T_d = T_C$

$$BANl = K\theta$$

$$\Rightarrow N = \frac{K\theta}{BAI}$$

$$A = 1 \times 10^{-4} \text{ m}^2$$

$$K = 0.15 \times 10^{-6} \frac{\text{N-m}}{\text{rad}}$$

$$B = 1.5 \times 10^{-3} \text{ wb/m}^2$$

$$I = 2 \times 10^{-3} \text{ A}$$

$$\theta = 90^\circ = \frac{\pi}{2} \text{ rad}$$

$$N = 785 \text{ ans.}$$

UNIT – II POTENTIOMETERS & INSTRUMENT TRANSFORMER

Working Principle of Potentiometer

This is a very basic instrument used for comparing emf two cells and for calibrating ammeter, voltmeter and watt-meter. The basic **working principle of potentiometer** is very very simple. Suppose we have connected two battery in head to head and tale to tale through a galvanometer. That means the positive terminals of both battery are connected together and negative terminals are also connected together through a galvanometer as shown in the figure below

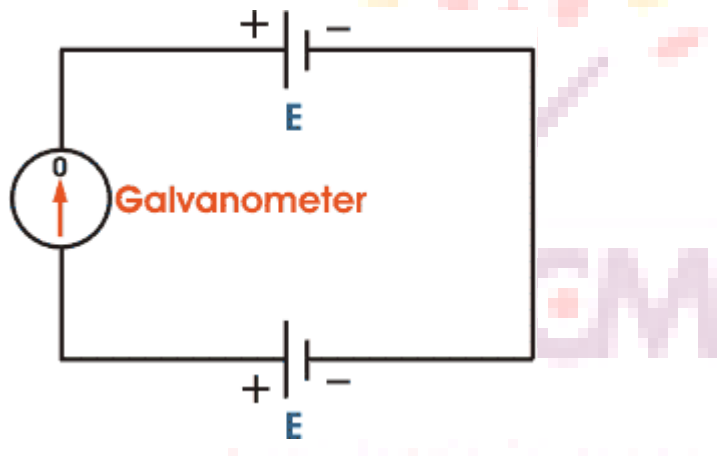

it is clear that if the voltage of both battery cells is exactly equal, there will be no circulating current in the circuit and hence the galvanometer shows null deflection. The **working principle of potentiometer** depends upon this phenomenon.

Now let's think about another circuit, where a battery is connected across a resistor via a switch and a rheostat as shown in the figure below voltage-drop-calculation/ across the resistor. As there is a voltage drop across the resistor, this portion of the circuit can be considered as a voltage source for other external circuits. That means anything connected across the resistor will get voltage. If the resistor has uniform cross section throughout its length, the electrical resistance per unit length of the resistor is also uniform throughout its length.

voltage drop per unit length of the resistor is also uniform. Suppose the current through the resistor is i A and resistance per unit length of the resistor is r Ω . Then the voltage

Electrical Measurements & Instrumentation (EE3101PC)

appears per unit length across the resistor would be 'ir' and say it is v volt.

positive terminal of a standard cell is connected to point A on the sliding resistor and negative terminal of the same is connected with a galvanometer. Other end of the galvanometer is in contact with the resistor via a sliding contact as shown in the figure above. By adjusting this

sliding end, a point like B is found where, there is no current through the galvanometer, hence no deflection of galvanometer.

That means emf of the standard cell is just balanced by the voltage-drop-calculation/ appears across AB. Now if the distance between point A and B is L , then it can be written emf of standard cell $E = Lv$ volt. As v (voltage drop per unit length of the sliding resistor) is known and L is measured from the scale attached to the resistor, the value of E i.e. emf of standard cell can also be calculated from the above simple equation very easily.

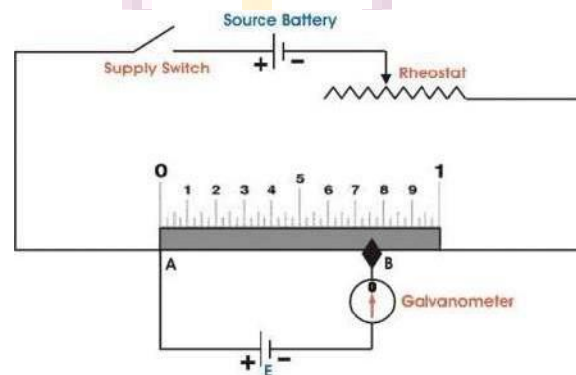

DC Crompton's Potentiometer :

DC Crompton's potentiometer is the laboratory-type potentiometer that is used to measure unknown emf effectively with a great degree of precision.

DC Crompton's potentiometer works on the principle of a slide wire potentiometer. In other words, the DC Crompton potentiometer is a modified version of a slide-wire potentiometer. It basically consists of a small slide wire which is circular in shape and a dial switch with calibrated resistors, as shown in the figure below.

In the figure shown,

- B = Battery
- Rh = Rheostat
- G = Galvanometer
- R = Protective resistance which is of order of $10\text{ K}\Omega$
- S = Double throw switch
- C = Standard cell

In DC Crompton's potentiometer, the dial switch is divided into fifteen steps with each step having a resistance of 10Ω . Hence, the total resistance of dial switch is equal to 150Ω ($15 \times 10 = 150$). The slide wire is in the form of a circular wire and has a resistance of 10Ω , with a single turn. A double-throw switch is provided for standardization and for measuring the unknown emf, one

Electrical Measurements & Instrumentation (EE3101PC)

after the other.

A protective resistance is connected in series with the galvanometer in order to protect the galvanometer and is shorted when the galvanometer reaches the balanced condition. As the working current provided by the battery is 10 mA, the voltage drop across each step is 0.1 V and hence it has a total range of 1.5 V ($1.5 \times 10 = 15$ V).

If circular slide wire has 200 divisions, then each division in slide wire has a resolution of 0.0005 V ($0.1/200 = 0.0005$). Hence, it is possible to measure the readings up to 0.0001 V with great precision and accuracy by taking readings up to 1/5th division in the scale.

First, the potentiometer is to be standardized to the standard cell voltage (1.0186 V) by keeping the dial switch at 1.0 V and slide wire at 0.0186. After making these adjustments, switch S is operated in calibrate mode and key k is closed and the rheostat is adjusted in such a way that, the galvanometer shows null deflection. With this, the potentiometer is standardized to the voltage of standard cell which is connected between the terminals 1 and 1'.

Now, the switch is thrown into the operating mode for measuring the unknown emf connected between terminals 2 and 2'. The value of unknown emf can be measured directly from the dial switch and circular slide wire, after balancing the galvanometer to show null deflection. In this way, an unknown emf can be measured with great precision using DC Crompton's potentiometer.

Standardization of DC Crompton's Potentiometer :

DC Crompton potentiometer is a laboratory-type potentiometer, with high precision. Here, the long slide wire is replaced with extension coils having the resistance same as that of the slide wire.

Standardization is defined as the process of adjusting the working current of the potentiometer such that the voltage drop across the section of slide wire is equal to the standard reference voltage. The following are the steps involved in the standardization of DC Crompton's potentiometer.

- Settings are made such that, the sum of the voltage across the dial resistors and the slide wire is equal to the standard cell voltage.
- The switch is closed to calibrate the positions and the rheostat is set for null deflection. The galvanometer key is tapped and the resistance is kept in the circuit to protect the galvanometer.
- As soon as zero deflection is obtained, the protective resistance is replaced by a short-circuit, and then final settings are done for null deflection using a rheostat.

Electrical Measurements & Instrumentation (EE3101PC)

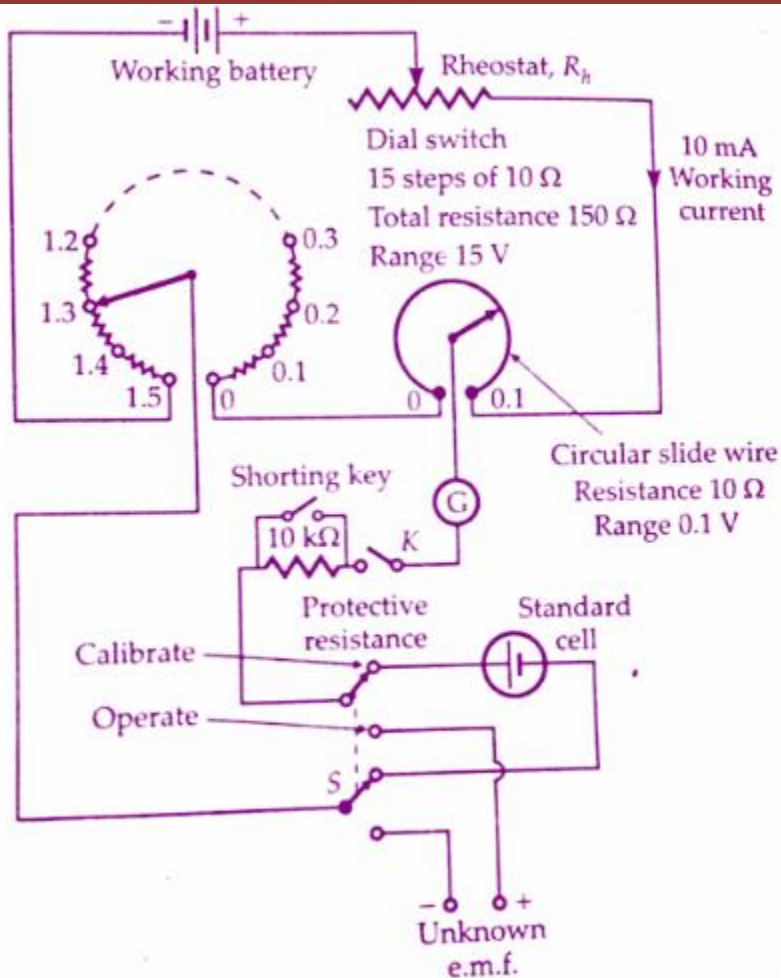

DC POTENTIOMETER CAN COMPARE EMFS OF TWO DIFFERENT CELLS

Two cells whose emf's are to be compared are joined as shown in the figure below. The positive terminals of the cells and source battery are joined together. The negative terminals of the cells are joined with the galvanometer in turn through a two way switch. The other end of the galvanometer is connected to a sliding contact on the resistor. Now by adjusting sliding contact on the resistor, it is found that the null deflection of galvanometer comes for first cell at a length of L on the scale and after positioning to way switch to second cell and then by adjusting the sliding contact, it is found that the null deflection of galvanometer comes for that cell at a length of L_1 on the scale. Let's think of the first cell as standard cell and its emf is E and second cell is unknown cell whose emf is E_1 . Now as per above explanation, $E = Lv$ volt and $L_1 = L_1v$ volt Dividing one equation by other, we get

$$\frac{E_1}{E} = \frac{L_1}{L}$$

As the emf of the standard cell is known, hence emf of the unknown cell can easily be

Electrical Measurements & Instrumentation (EE3101PC)

determined.

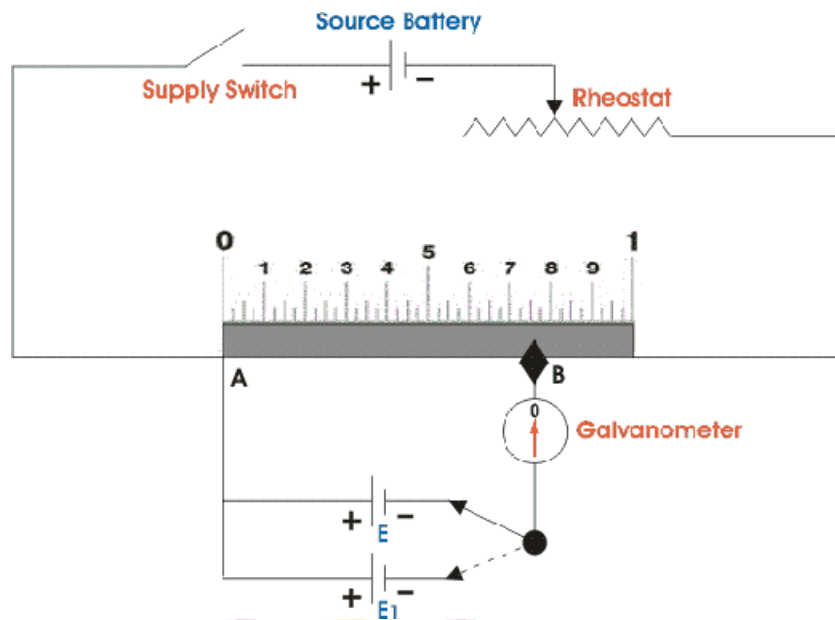

Measurement of current

The unknown current I , whose value is to be measured is passed through a resistor R . The value of the resistor is such that voltage drop across it may not exceed the range of the potentiometer.

The circuit diagram of current measurement by potentiometer is shown below:

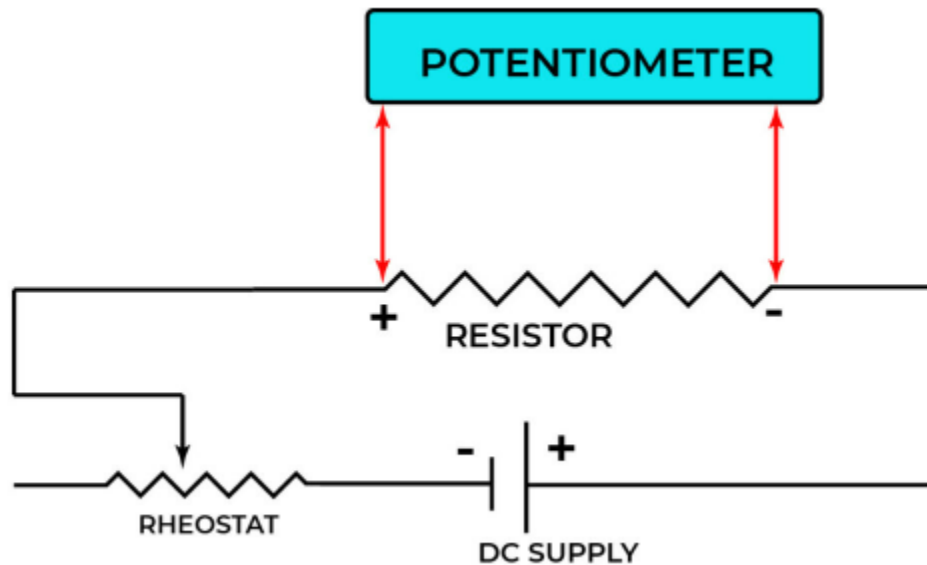

So, the value of the unknown current is the voltage drop across the resistor divided by the value of the resistor.

Electrical Measurements & Instrumentation (EE3101PC)

$$I = V/R$$

Measurement of resistance

An unknown resistance is connected in series with a standard resistance S . A rheostat controls the current in the circuit. A two-pole double throw switch is also used in the circuit. The circuit is shown below:

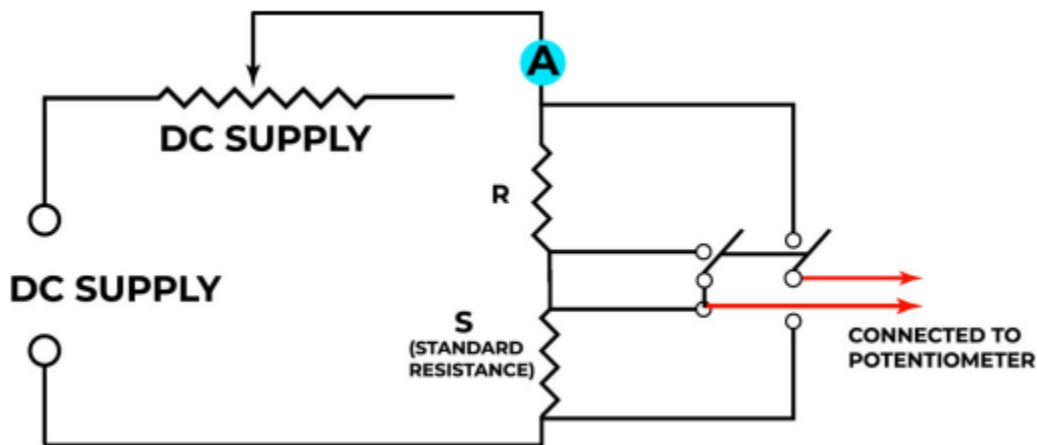

When the two poles double throw switch is put in position 1, the unknown resistance is connected to the potentiometer.

Let the reading of the potentiometer be V_R

$$V_R = IR \quad (i)$$

Now the switch is put in position 2, this connects the standard resistor S to the potentiometer.

Let the reading of potentiometer be V_S

$$V_S = IS \quad (ii)$$

From i and ii

$$V_R/V_S = IR/IS$$

$$R = (V_R/V_S) * S$$

The value of R is calculated accurately.

Measurement of power

In the measurement of power, 2 measurements are made. One is across the resistor S connected in series with the load and the other is across the output terminals of voltage—ratio box.

The load current is calculated from the voltage drop across the standard resistor

Electrical Measurements & Instrumentation (EE3101PC)

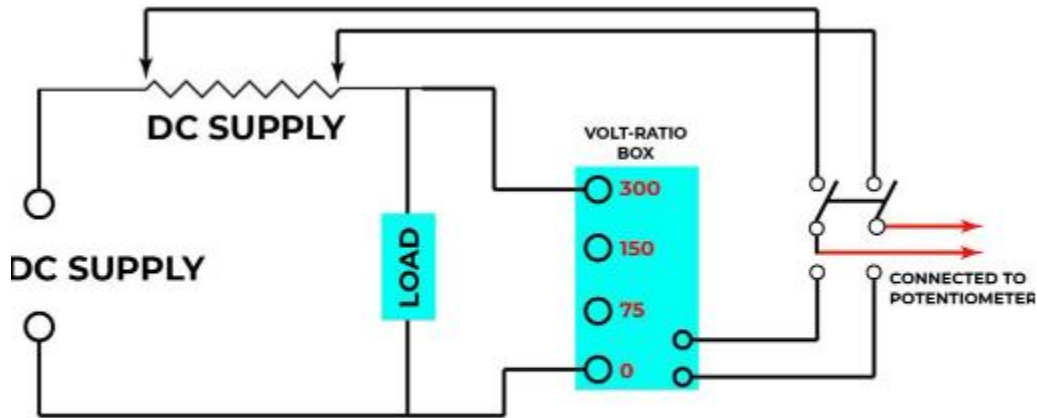

Power measurement by potentiometer

The voltage drop across the load is calculated by the potentiometer reading across the output terminal of the voltage-ratio box

Load current $I = V_S/S$

Where V_S is the voltage drop across the standard resistor

The voltage drop across the load $V_L = kV_R$

Where, k = multiplying factor of the voltage-ratio box.

So, the power consumed, $P = V_L I$

$P = K * V_R * (V_S/S)$

AC Potentiometer

The Potentiometer is an instrument which measures unknown voltage by balancing it with a known voltage. The known source may be DC or AC. The working phenomenon of DC potentiometer and **AC potentiometer** is same. But there is one major difference between their measurements, DC potentiometer only measures the magnitude of the unknown voltage. Where as, AC potentiometer measures both the magnitude and phase of unknown voltage by comparing it with known reference. There are two types of AC potentiometers:

1. Polar type potentiometer.
2. Coordinate type potentiometer.

Polar type Potentiometer

In such type of instruments, two separate scales are used to measure magnitude and phase angle on some reference of the unknown e.m.f. There is a provision on the scale that it could read phase angle up to 3600. It has electro-dynamometer type ammeter along with DC potentiometer and phase-shifting transformer which is operated by single phase supply. In phase-shifting transformer, there is a combination of two ring-shaped laminated steel stators connected perpendicularly to each other as shown in the figure. One is directly connected to power supply and the other one is connected in series with variable resistance

Electrical Measurements & Instrumentation (EE3101PC)

and capacitor. The function of the series components is to maintain constant AC supply in the potentiometer by doing small adjustments in it. Between the stators, there is laminated rotor having slots and winding which supplies voltage to the slide-wire circuit of the Potentiometer. When current start flowing from stators, the rotating field is developed around the rotor and due to it e.m.f. is induced in the rotor winding. The phase displacement of the rotor emf is equal to rotor movement angle from its original position and it is related to stator supply voltage. The whole arrangement of winding are done in such a way that the magnitude of the induced emf in the rotor may change but it does not affect the phase angle and it can be read on the scale fixed on the top of the instrument.

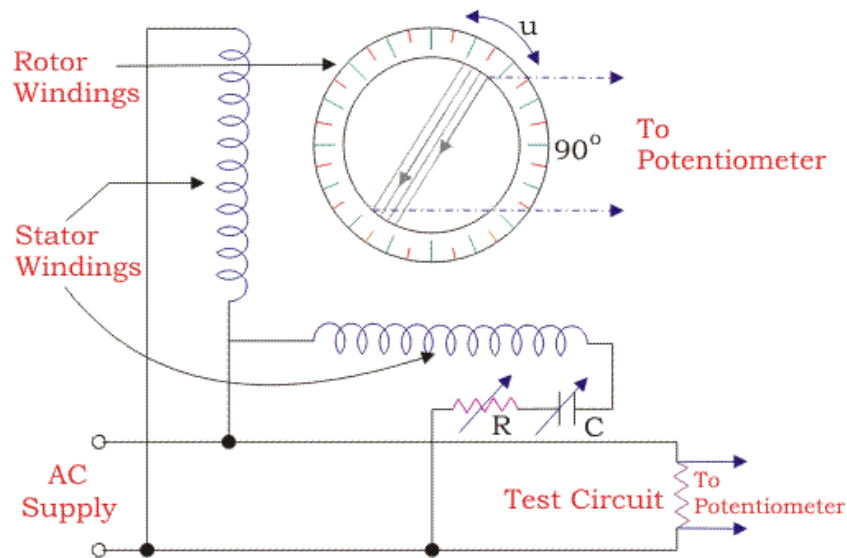

Polar Type Potentiometer

The induced emf in rotor winding by stator winding 1 can be expressed as

$$E_1 = K I \sin \omega t \cos \phi \dots \dots \dots (1)$$

The induced emf in the rotor winding by the stator winding 2,

$$\begin{aligned} E_2 &= K I \sin(\omega t + 90^\circ) \cos(\phi + 90^\circ) \\ &= -K I \cos \omega t \sin \phi \dots \dots \dots (2) \end{aligned}$$

From equation (1) and (2), we get

$$E = K I (\sin \omega t \cos \phi - \cos \omega t \sin \phi)$$

Therefore, resultant induced emf in the rotor winding due to two stator winding

$$E = K I \sin (\omega t - \phi) \text{ Where, } \phi \text{ gives the phase angle.}$$

COORDINATE TYPE POTENTIOMETER

In **coordinate AC potentiometer**, two separate potentiometers are caged in one circuit as shown in the figure. The first one is named as the in-phase potentiometer which is used to measure the in-phase factor of an unknown e.m.f. and the other one is named as quadrature potentiometer which measures quadrature part of the unknown e.m.f. the sliding contact AA' in the in-phase potentiometer and BB' in quadrature potentiometer are used for obtaining the desired current in the circuit. By adjusting rheostat R and R' and sliding contacts, the current in the quadrature potentiometer becomes equal to the current in the in-phase potentiometer and a variable galvanometer shows the null value. S₁ and S₂ are signs changing switches which are used to change the polarity of the test voltage if it is required for balancing the Potentiometer. There are two step-down transformers T₁ and T₂ which isolate potentiometer from the line and give an earthed screens protection between the winding. It also supplies 6 volts to potentiometers. Now to measure unknown e.m.f. its terminals are connected across sliding contacts AA' using selector switch S₃. By doing some adjustments in sliding contacts and rheostat, the whole circuit gets balanced and galvanometer reads zero at the balanced condition. Now the in-phase component V_A of the unknown e.m.f. is obtained from the in-phase potentiometer and quadrature component V_B is obtained from quadrature potentiometer.

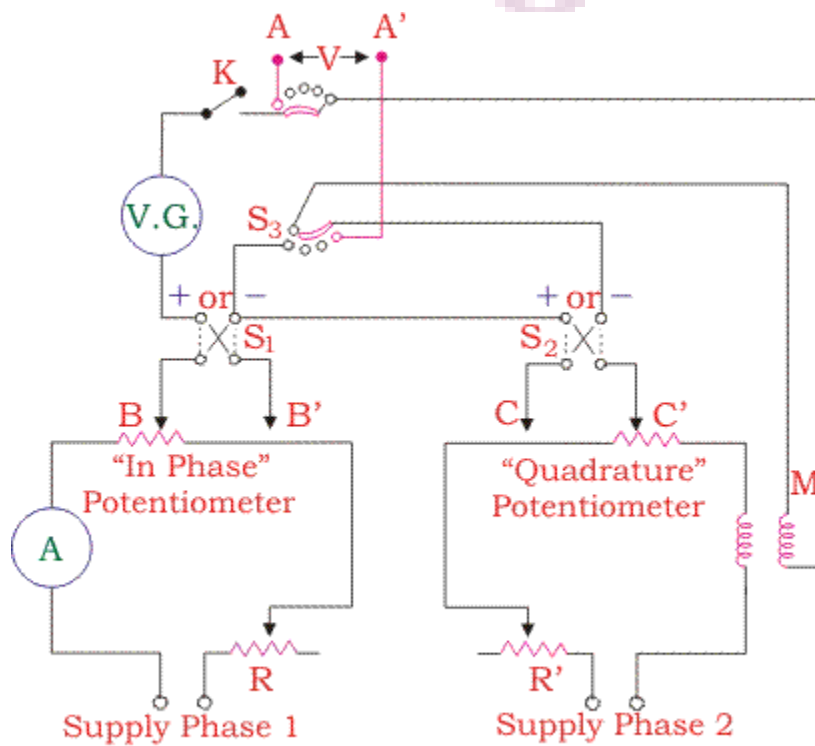

Coordinate AC potentiometer

$$V = (V_A^2 + V_B^2)^{1/2}$$

Thus, the resultant voltage of the coordinate

AC potentiometer is

And the phase angle is given $\phi = \tan^{-1}(V_B/V_A)$
by

Applications of AC Potentiometer

1. Measurement of self-inductance.
2. Calibration of voltmeter.
3. Calibration of Ammeter.
4. Calibration of wattmeter.



INSTRUMENT TRANSFORMERS

Introduction of Instrument Transformers

Instrument Transformers are used in AC system for measurement of electrical quantities i.e. voltage, current, power, energy, power factor, frequency. Instrument transformers are also used with protective relays for protection of power system. Basic function of Instrument transformers is to step down the AC System voltage and current. The voltage and current level of power system is very high. It is very difficult and costly to design the measuring instruments for measurement of such high level voltage and current. Generally measuring instruments are designed for 5 A and 110 V.

The measurement of such very large electrical quantities, can be made possible by using the Instrument transformers

Advantages of Instrument Transformers

1. The large voltage and current of AC Power system can be measured by using small rating measuring instrument i.e. 5 A, 110 – 120V.
2. By using the instrument transformers, measuring instruments can be standardized. Which results in reduction of cost of measuring instruments. More over the damaged measuring instruments can be replaced easy with healthy standardized measuring instruments.
3. Instrument transformers provide electrical isolation between high voltage power circuit and measuring instruments. Which reduces the electrical insulation requirement for measuring instruments and protective circuits and also assures the safety of operators.
4. Several measuring instruments can be connected through a single transformer to power system.
5. Due to low voltage and current level in measuring and protective circuit, there is low power consumption in measuring and protective circuits.

Types of Instrument Transformers

Instrument transformers are of two types –

1. Current Transformer(C.T.)
2. Potential Transformer(P.T.)

Current Transformer (C.T.)

Current transformer is used to step down the current of power system to a lower level to make it feasible to be measured by small rating Ammeter (i.e. 5A ammeter). A typical connection diagram of a current transformer is shown in figure below.

Electrical Measurements & Instrumentation (EE3101PC)

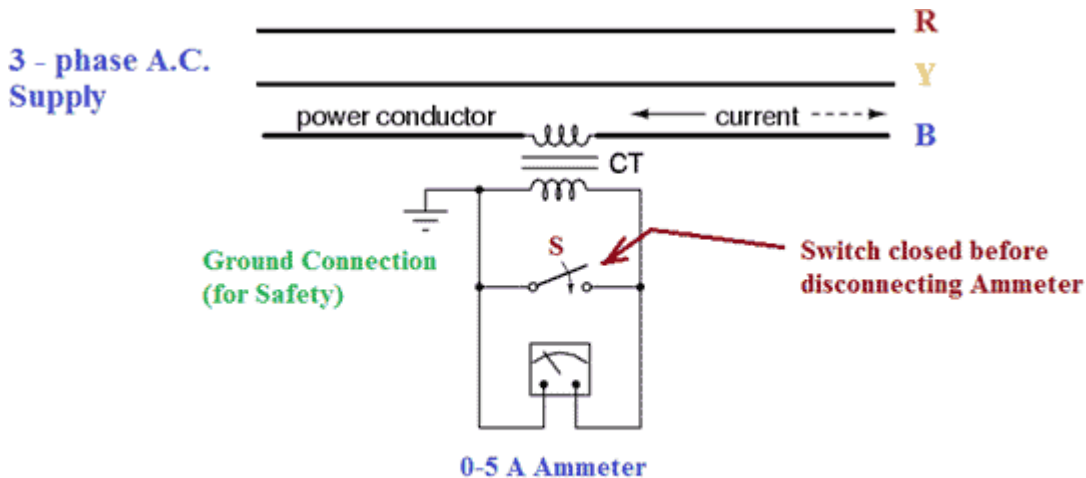

Current Transformer (C.T.)

Primary of C.T. is having very few turns. Sometimes bar primary is also used. Primary is connected in series with the power circuit. Therefore, sometimes it also called series transformer.

The secondary is having large no. of turns. Secondary is connected directly to an ammeter. As the ammeter is having very small resistance. Hence, the secondary of current transformer operates almost in short circuited condition. One terminal of secondary is earthed to avoid the large voltage on secondary with respect to earth. Which in turns reduce the chances of insulation breakdown and also protect the operator against high voltage. More ever before disconnecting the ammeter, secondary is short circuited through a switch 'S' as shown in figure above to avoid the high voltage build up across the secondary.

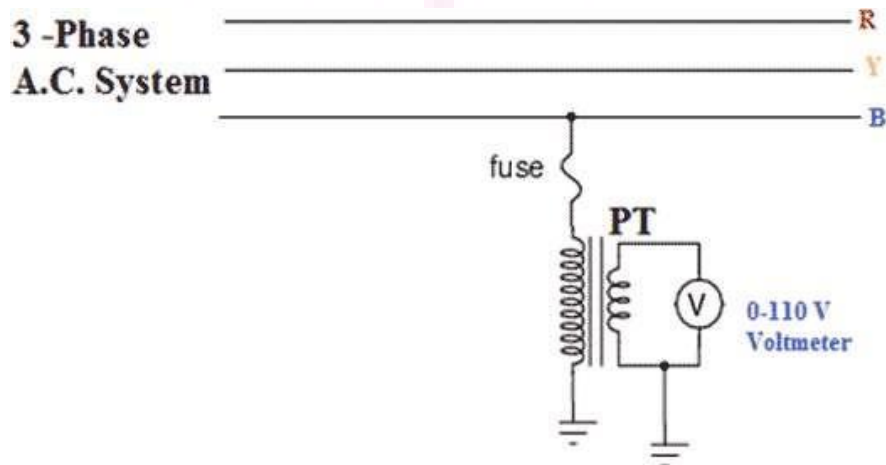

Potential Transformer (P.T.)

Sl. No.	Current Transformer (C.T.)	Potential Transformer (P.T.)
1	Connected in series with power circuit.	Connected in Parallel with Power circuit.
2	Secondary is connected to Ammeter.	Secondary is connected to Voltmeter.
3	Secondary works almost in short circuited condition.	Secondary works almost in open circuited condition.
4	Primary current depends on power circuit current.	Primary current depends on secondary burden.
5	Primary current and excitation vary over wide range with change of power circuit current	Primary current and excitation variation are restricted to a small range.
6	One terminal of secondary is earthed to avoid the insulation break down.	One terminal of secondary can be earthed for Safety.
7	Secondary is never be open circuited.	Secondary can be used in open circuit condition.

Error in PT or Potential Transformer or VT or Voltage Transformer

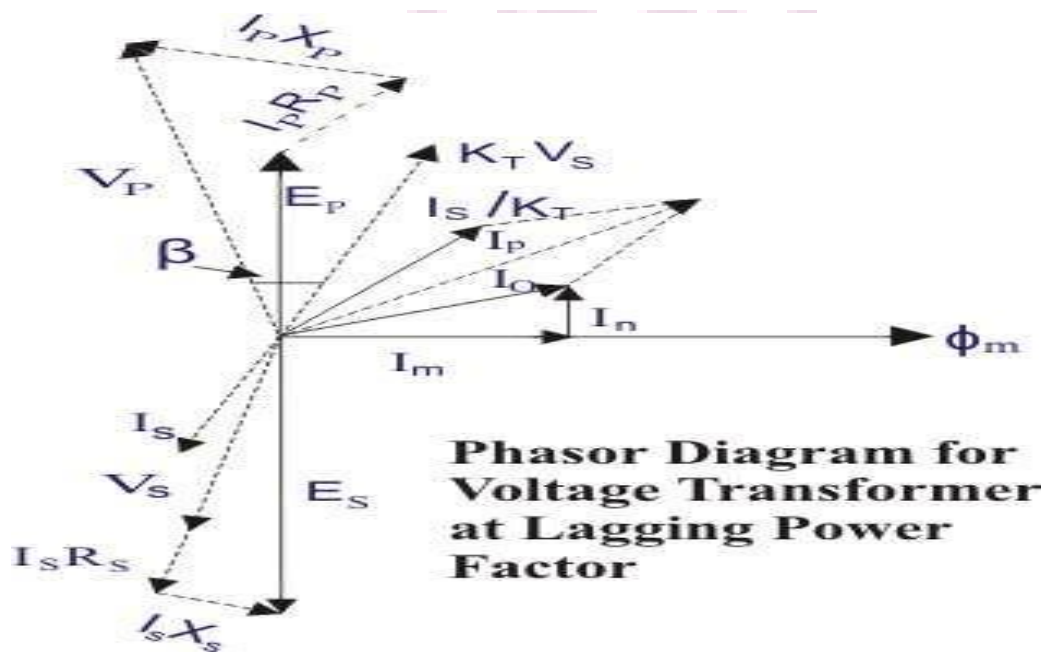

I_s - Secondary current.

E_s - Secondary induced emf.

V_s - Secondary terminal voltage

R_s - Secondary winding resistance.

X_s - Secondary winding reactance.

I_p - Primary current. E_p - Primary induced emf.

V_p - Primary terminal voltage. R_p - Primary winding resistance. X_p - Primary winding reactance.

K_T - Turns ratio = Numbers of primary turns/number of secondary turns. I_0 - Excitation current.

I_m - Magnetizing component of I_0 . I_w - Core loss component of I_0 .

Φ_m - Main flux.

β - Phase angle error.

As in the case of current transformer and other purpose electrical power transformer, total primary current I_p is the vector sum of excitation current and the current equal to reversal of secondary current multiplied by the ratio $1/K_T$.

$$\text{Hence, } I_p = \frac{I_0 + I_s}{K_T}$$

If V_p is the system voltage applied to the primary of the PT, then voltage drops due to resistance and reactance of primary winding due to primary current I_p will come into picture. After subtracting this voltage drop from V_p , E_p will appear across the primary terminals. This E_p is equal to primary induced emf. This primary emf will transform to the secondary winding by mutual induction and transformed emf is E_s . Again this E_s will be dropped by secondary winding resistance and reactance, and resultant will actually appear across the burden terminals and it is denoted as V_s . So, if system voltage is V_p , ideally V_p/K_T should be the secondary voltage of PT, but in reality; actual secondary voltage of PT is V_s .

Voltage Error or Ratio Error in Potential Transformer (PT) or Voltage Transformer (VT)

The difference between the ideal value V_p/K_T and actual value V_s is the voltage error or ratio error in a potential transformer, it can be expressed as,

$$\% \text{ voltage error} = \frac{V_p - K_T \cdot V_s}{V_p} \times 100 \%$$

Phase Error or Phase Angle Error in Potential or Voltage Transformer

The angle ' β ' between the primary system voltage V_p and the reversed secondary voltage vectors $K_T \cdot V_s$ is the phase error.

Cause of Error in Potential Transformer

The voltage applied to the primary of the potential transformer first drops due to the internal impedance of the primary. Then it appears across the primary winding and then transformed proportionally to its turns ratio, to the secondary winding.

This transformed voltage across the secondary winding will again drop due to the internal impedance of the secondary, before appearing across burden terminals.

This is the reason of errors in **potential transformer**.

Ratio Error Phase Angle Error in Current Transformer

Transformer Definition of Instrument Transformer

Instrument transformers means **current transformer** and voltage transformer are used in electrical power system for stepping down currents and voltages of the system for metering and protection purpose.

Current Transformer (CT)

A CT is an instrument transformer in which the secondary current is substantially proportional to primary current and differs in phase from it by ideally zero degree.

Error in Current Transformer or CT

But in an actual CT, errors with which we are connected can best be considered through a study

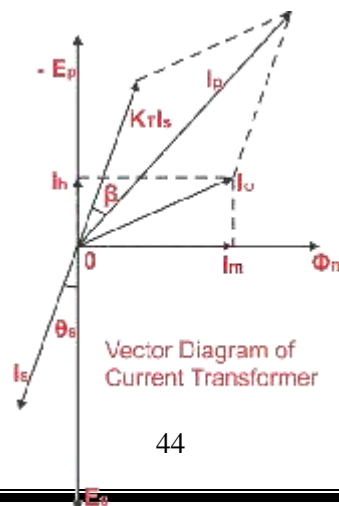

of phasor diagram for a CT

, I_s - Secondary current

E_s - Secondary

induced emf. I_p -

Primary current.

E_p - Primary induced emf.

K_T - Turns ratio = Numbers of secondary turns/number of primary turns. I_0 - Excitation current.

I_m - Magnetizing component

of I_0 . I_w - Core loss

component of I_0 .

Φ_m - Main flux. Let us take flux as reference.

EMF E_s and E_p lags behind the flux by 90° . The magnitude of the passers E_s and E_p are proportional to secondary and primary turns. The excitation current I_0 which is made up of two components I_m and I_w . The secondary current I_s lags behind the secondary induced emf E_s by an angle Φ_s . The secondary current is now transferred to the primary side by reversing I_s and multiplied by the turns ratio K_T . The total current flows through the primary I_p is then vector sum of $K_T I_s$ and I_0 .

The Current Error or Ratio Error in Current Transformer or CT From above phasor diagram it is clear that primary current I_p is not exactly equal to the secondary current multiplied by turns ratio, i.e. $K_T I_s$. This difference is due to the primary current is contributed by the core excitation current. The error in current transformer introduced due to this difference is called current error of CT or some times ratio error in current transformer.

$$\text{Hence, the percentage current error} = \frac{|I_p| - |K_T I_s|}{I_p} \times 100 \%$$

Phase Error or Phase Angle Error in Current Transformer

For an ideal CT the angle between the primary and reversed secondary current vector is zero. But for an actual CT there is always a difference in phase between two due to the fact that primary current has to supply the component of

the exiting current. The angle between the above two phases is termed as phase angle error in current transformer or CT. Here in the phasor diagram it is β the phase angle error is usually expressed in minutes.

Cause of Error in Current Transformer

The total primary current is not actually transformed in CT. One part of the primary current is consumed for core excitation and remaining is actually transformers with turns ratio of CT so there is **error in current transformer** means there are both **ratio error in current transformer** as well as a **phase angle error in current transformer**.

How to Reduce Error in Current Transformer

It is desirable to reduce these errors, for better performance. For achieving minimum error in current transformer, one can follow the following,

1. Using a core of high permeability and low hysteresis loss magnetic materials.
2. Keeping the rated burden to the nearer value of the actual burden.
3. Ensuring minimum length of flux path and increasing cross-sectional area of the core, minimizing joint of the core.
4. Lowering the secondary internal impedance.

NRCM

UNIT – III MEASUREMENT OF POWER & ENERGY

Dynamometer type wattmeter works on very simple principle and this principle can be stated as when any current carrying conductor is placed inside a magnetic field, it experiences a mechanical force and due to this mechanical force deflection of conductor takes place.

Construction and Working Principle of Electrodynamometer Type

Wattmeter Now let us look at constructional details of electro-dynamometer. It consists of following parts. **Moving Coil** Moving coil moves the pointer with the help of spring control instrument. Limited current flows through the moving coil so as to avoid heating. So in order to limit the current we have connected the high value resistor in series with the moving coil. The moving coil is air cored and is mounted on a pivoted spindle and can move freely. In **electrodynamometer type wattmeter**, moving coil works as pressure coil. Hence moving coil is connected across the voltage and thus the current flowing through this coil is always proportional to the voltage

Fixed Coil

The fixed coil is divided into two equal parts and these are connected in series with the load, therefore the load current will flow through these coils. Now the reason is very obvious of using two fixed coils instead of one, so that it can be constructed to carry considerable amount of electric current. These coils are called the current coils of **electrodynamometer type wattmeter**. Earlier these fixed coils are designed to carry the current of about 100 amperes but now the modern wattmeter are designed to carry current of about 20 amperes in order to save power.

Control System Out of two controlling systems i.e.

1. Gravity control
2. Spring control, only spring controlled systems are used in these types of wattmeter. Gravity controlled system cannot be employed because they will be appreciable amount of errors.

Damping System Air friction damping is used, as eddy current damping will distort the weak operating magnetic field and thus it may lead to error. **Scale** There is uniform scale which is used in these types of instrument as moving coil moves linearly over a

range of 40 degrees to 50 degrees on either side. Now let us derive the expressions for the controlling torque and deflecting torques. In order to derive these expressions let us consider the circuit diagram given below:

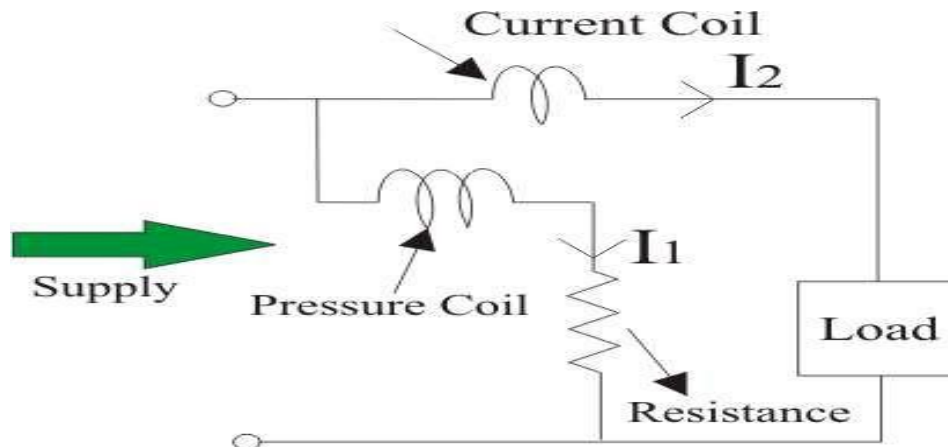

We know that instantaneous torque in electro dynamic type instruments is directly proportional to product of instantaneous values of currents flowing through both the coils and the rate of change of flux linked with the circuit. Let I_1 and I_2 be the instantaneous values of currents in pressure and current coils respectively. So the expression for the torque can be written as:

$$T = I_1 \times I_2 \times \frac{dM}{dx}$$

Where, x is the angle. Now let the applied value of voltage across the pressure coil be $v = \sqrt{2}V \sin \omega t$. Assuming the electrical resistance to the pressure coil be very high hence we can neglect reactance with respect to its resistance. In this the impedance is equal to its electrical resistance therefore it is purely resistive. The expression for instantaneous current can be written as $I_2 = v / R_p$ where R_p is the resistance of pressure coil

$$I_2 = \sqrt{2} \times \frac{V \sin \omega t}{R_p}$$

If there is phase difference between voltage and electric current, then expression for instantaneous current through

$$I_1 = I(\text{current coil}) = \sqrt{2} I \sin(\omega t - \phi) \text{ can be written as}$$

As current through the pressure coil is very very small compared to the current through current coil hence current through the current coil can be considered as equal to total load

$$\sqrt{2} \times \frac{V \sin \omega t}{R_p} \times \sqrt{2} \times I \times \sin(\omega t - \phi) \times \frac{dM}{dx}$$

current. Hence the

instantaneous value of torque can be written as

Average value of deflecting torque can be obtained by integrating the instantaneous torque from limit 0 to T, where T is the time period of the cycle.

$$T_d = \text{deflecting torque} = \frac{VI}{R_p} \cos \phi \times \frac{dM}{dx}$$

Controlling torque is given by $T_c = K_x$ where K is spring constant and x is final steady state value of deflection.

Advantages of Electrodynamicometer Type

Wattmeter Following are the advantages of electrodynamicometer type wattmeter and they are written as follows:

1. Scale is uniform upto a certain limit.
2. They can be used for both to measure ac as well dc quantities as scale is calibrated for both.

Errors in Electrodynamicometer Type Wattmeter

Following are the errors in the electrodynamicometer type watt meters:

1. Errors in the pressure coil inductance.
2. Errors may be due to pressure coil capacitance.
3. Errors may be due to mutual inductance effects.

4. Errors may be due connections.(i.e. pressure coil is connected after current coil)
5. Error due to Eddy currents.
6. Errors caused by vibration of moving system.
7. Temperature error.
8. Errors due to stray magnetic field.

What is Low Power Factor Wattmeter?

As the name suggests the low power factor meter are the instruments that measures lower values of power factor accurately.

There are two main reasons that would suggests us that we should not use ordinary wattmeter in measuring the low value of power factor.

1. The value of deflecting torque is very low even though we fully excite the current and pressure coils.
2. Errors due pressure coil inductance.

some modification or adding some new features we can use modified electro dynamic wattmeter or low power factor to measure the low power factor accurately.

(1) The electrical resistance of the ordinary wattmeter's pressure coil is reduced to low value such that current in the pressure coil circuit is increased, thus it leads to. In this category two cases diagrams arises and these are shown below:

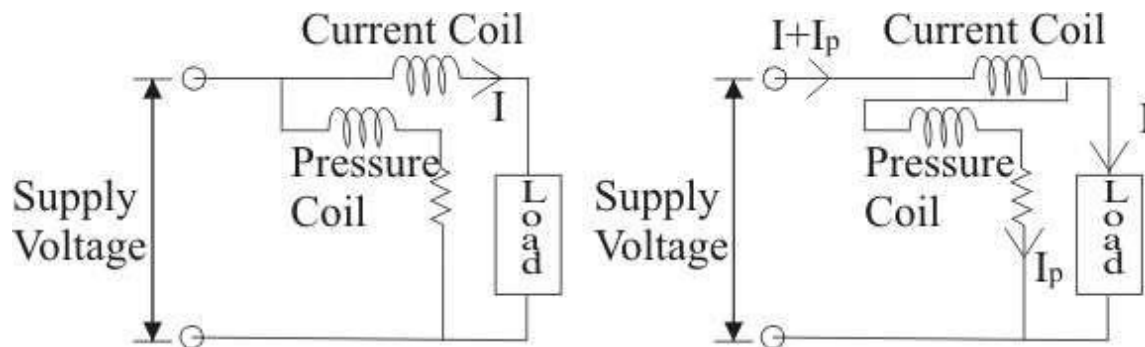

both the ends of the pressure coil is connected to supply side (i.e. current coil is in series with the load). The supply voltage is equal to the voltage across the pressure coil. Thus in this case we

have power shown by the first wattmeter is equal to the power loss in the load plus power loss in the current coil.

$$\text{Mathematically } P_1 = \text{power consumed by load} + I^2 R_1$$

In the second category, the current coil is not in series with the load and the voltage across the pressure coil is not equal to the applied voltage. The voltage across pressure coil is equal to the voltage across the load. In this power shown by the second watt meter is equal to the power loss in the load plus the power loss in the pressure coil.

$$\text{Mathematically } P_2 = \text{power consumed by load} + I^2 R_2$$

From the above discussion we conclude that in both cases we have some amount of errors hence there is need to do some modification in above circuits to have minimum error.

The modified circuit is shown below: We have used here a special coil called compensating coil, it carries current equal to the sum of two currents i.e load current plus pressure coil current. The pressure coil is placed such that the field produced by the compensating coil is opposed by the field produced by pressure coil as shown in the above circuit diagram.

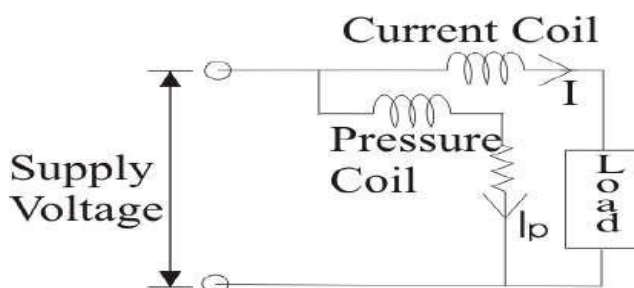

Thus the net field is due to the current I only. Hence by this way error caused by pressure coil can be neutralised.

(2) We require compensating coil in the circuit in order to make the low power factor meter. It is the second modification that we have discussed in detail above.

(3) Now the third point deals with the compensation of the inductance of pressure coil, which can be achieved by doing modification in above circuit.

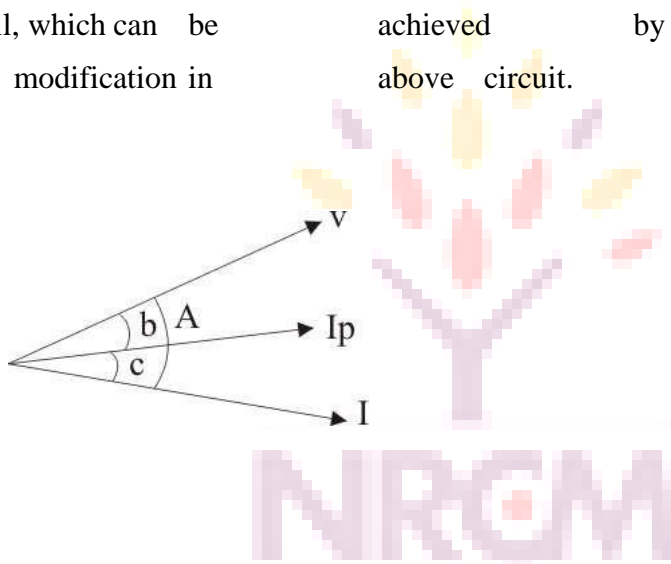

Now let us derive an expression for the correction factor for pressure coil inductance. And from this correction factor we are going to derive an expression for error due to inductance of pressure coil. If we consider the inductance of pressure coil we don't have voltage across pressure in phase with the applied voltage. Hence in that case it lags by an angle

$$b = \tan^{-1} \frac{W_l}{R + r_p}$$

Where, R is electrical resistance in series with pressure coil, r_p is pressure coil resistance, here we also conclude that the current in the current coil is also lagging by some angle with the current in pressure coil. And this angle is given by $C = A -$

b. At this time reading of the voltmeter is given by

$$\frac{VI \cos(C) \frac{dM}{dx}}{K + R_p} \dots \dots \dots (1)$$

Where, R_p is (r_p+R) and x is angle. If we ignore the effect of inductance of pressure i.e putting $b = 0$ we have expression for true power as

$$\frac{VI \cos(A) \frac{dM}{dx}}{K \cdot R_p} \dots \dots \dots (2)$$

On taking ratio of equations (2) and (1) we have expression for correction factor as written below:

$$\frac{\cos(A)}{\cos(b)\cos(A - b)}$$

And from this correction factor error can be calculated as

$$\text{Error} = \{1 - (\text{correction factor})\} \times (\text{actual reading of the voltmeter})$$

On substituting the value of correction factor and taking suitable approximation we have expression for error as $VI \sin(A) \cdot \tan(b)$.

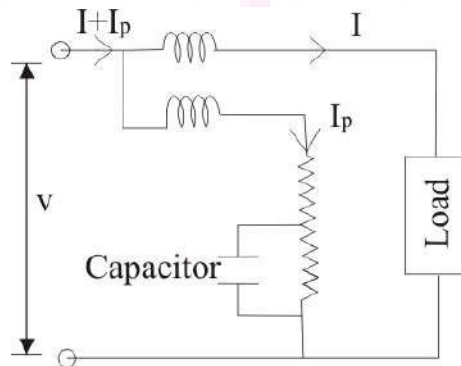

Now we know that the error caused by pressure coil inductance is given by the expression $e = VI \sin(A) \tan(b)$, if power factor is low (i.e in our case the value of ϕ is large hence we have large error). Thus in order to avoid this situation we have connect the variable series resistance with a capacitor as shown in the above

figure. This final modified circuit so obtained is called **low power factor meter**. A modern low power factor meter is designed such that it gives high accuracy while measuring power factors even lower than 0.1.

TWO-ELEMENT WATTMETER FOR THREE-PHASE SYSTEM

Two single-phase wattmeters were used to measure the power in a three-phase, three-wire system. The two single-phase wattmeters can be combined into a single instrument

The scale of this instrument indicates the sum or difference of the power values indicated by the separate meters. To make the single wattmeter, two sets of potential coils are mounted on a single shaft. Also, two sets of field coils are mounted on the instrument frame so that they have the proper relationship to the armature coils. In this way, each of two power measuring mechanisms develops a torque that is proportional to the power in the circuit to which it is connected. These torque values are added to obtain the total power in the three-phase, three-wire circuit. If the power factor of the system is less than 0.5, the torque of one mechanism opposes that of the second mechanism. The difference between the torque values is the power indication.

A wattmeter containing two dynamometer mechanisms is called a *two-element wattmeter*.

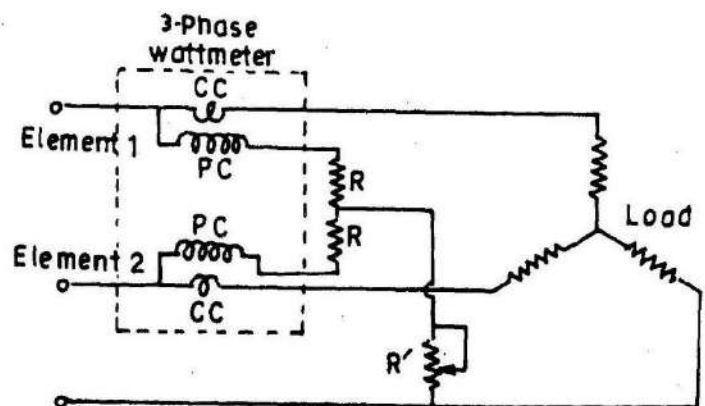
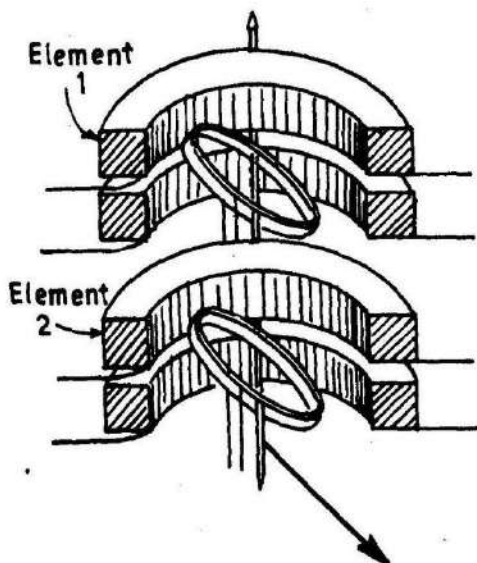

Now the pressure coil is split into two parts one is purely inductive another is purely resistive as shown in the diagram by resistor and inductor. At present the reference plane is making an angle A with coil 1. And the angle between both the



WATT HOUR METER

Watt-hour meter is in fact a measuring device which can evaluate and records the electrical power passing through a circuit in a certain time. By implementing the Watt-hour meter, we can know how much amount of electrical energy is used by a consumer or a residence or an electrically powered device or a business.

Electrical utilities install these meters at their consumer's place to evaluate the electrical usage for the purpose of billing. The reading is taken in each one billing period. Usually, the billing unit is Kilowatt-hour (kWh). This is equal to the total usage of electrical energy by a consumer of one kilowatt during a period of one hour and it is also equal to 3600000 joules. The Watt-Hour Meter is often referred as energy meter or electric meter or electricity meter or electrical meter. Mainly the watt-hour meter comprises of a tiny motor and a counter. The motor will operate by diverting exact fraction of current which is flowing in the circuit to be measured.

Electromechanical Type Induction Meter

In this type of meter, a non-magnetic and electrically conductive aluminium metal disc is made to revolve in a magnetic field. The rotation is made possible with the power passing through it. The rotation speed is proportional to the power flow through the meter. Gear trains and counter mechanisms are incorporated to integrate this power. This meter works by counting the total number of revolutions and it is relative to the usage of energy.

A series magnet is connected in series with the line and that comprises of a coil of few turns with thick wire. A shunt magnet is connected in shunt with the supply and comprises of a coil of large number of turns with thin wire. A braking magnet which is a permanent magnet is included for stopping the disc at the time of power failure and to place the disc in position. This is done by applying a force opposite to the rotation of the disc.

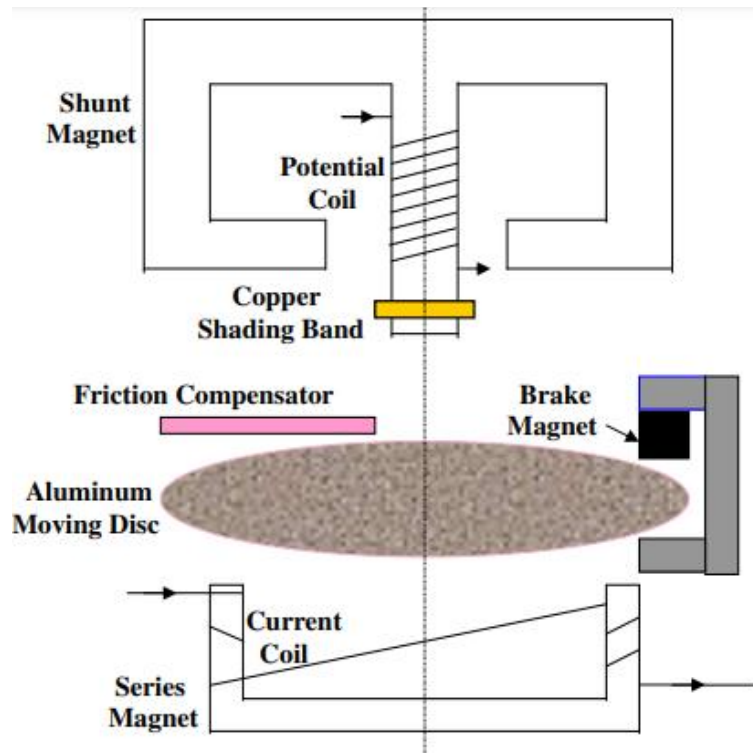

A flux is produced by the series magnet that is directly proportional to the current flow and another flux is produced by the shunt magnet corresponding to the voltage. Because of the inductive nature, these two fluxes lag each other by 90° . An eddy current is developed in the disc which is the interface of the two fields. This current is produced by a force that is corresponding to the product of instantaneous current, voltage and the phase angle among them. A brake torque is

developed on the disc by the braking magnet positioned over one side of the disc. The speed of the disc becomes constant when the following condition is achieved,

Braking torque = Driving torque. The gear arrangement linked with the shaft of the disc is implemented for recording the number of revolution. This is for single phase AC measurement. Additional number of coils can be implemented for different phase configuration.

$$Power = \frac{3600.Kh}{\text{time in sec for one revolution of the disc}}$$

INDUCTION TYPE METERS

The principle of working and construction of *induction type meter* is very simple and easy to understand that's why these are widely used in measuring energy in domestic as well as industrial world. In all induction meters we have two fluxes which are produced by two different alternating currents on a metallic disc. Due to alternating fluxes there is an induced emf, the emf produced at one point (as shown in the figure given below) interacts with the alternating current of the other side resulting in the production of torque

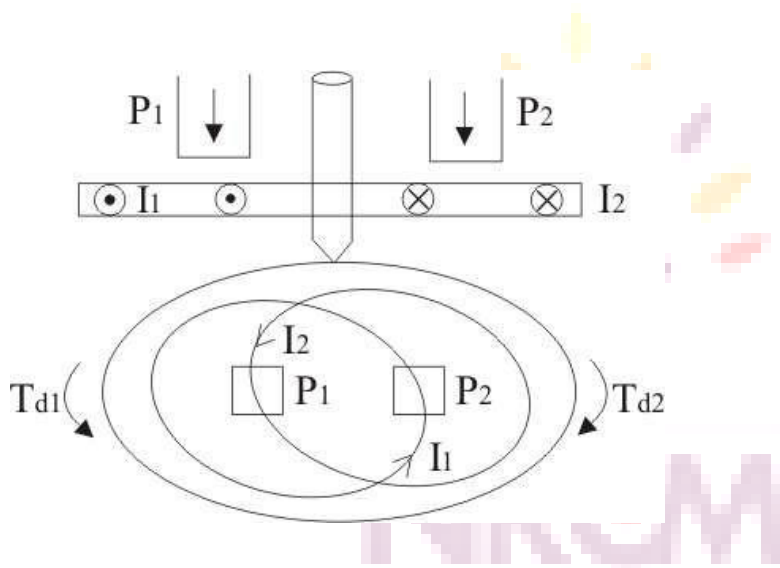

Similarly, the emf produced at the point two interacts with the alternating current at point one, resulting in the production of torque again but in opposite direction. Hence due to these two torques which are in different directions, the metallic disc moves. This is basic principle of working of an **induction type meters**. Now let us derive the mathematical expression for deflecting torque. Let us take flux produced at point one be equal to F_1 and the flux and at point two be equal to F_2 . Now the instantaneous values of these two flux can written as:

$$F_1 = F_{m1} \sin \omega t, \quad F_2 = F_{m2} \sin(\omega t - B)$$

Where, F_{m1} and F_{m2} are respectively the maximum values of fluxes F_1 and F_2 ,

B is phase difference between two fluxes. We can also write the expression

for induced emf's

$$E_1 = -\frac{d(F_1)}{dt} \text{ and } E_2 = -\frac{d(F_2)}{dt}$$

Thus we have the expression for eddy currents at point one is

$$I_1 = \frac{E_1}{Z} = K \times f \times F_1$$

Where, K is some constant and f is frequency. Let us draw phasor diagram clearly showing F_1 , F_2 , E_1 , E_2 , I_1 and I_2 . From phasor diagram, it clear that I_1 and I_2 are respectively lagging behind E_1 and E_2 by angle A

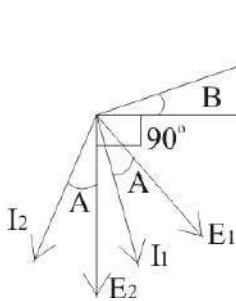

The angle between F_1 and F_2 is B. From the phasor diagram the angle between F_2 and I_1 is $(90 - B + A)$ and the angle between F_1 and I_2 is $(90 + B + A)$. Thus we write the expression for deflecting torque as

$$T_{d1} = K \times F_2 \times I_1 \times \cos(90 - B + A) = K \times F_1 \times F_2 \times \frac{f}{Z} \cos(90 - B + A),$$

Similarly the expression for T_{d2} is

$$T_{d2} = K \times F_1 \times F_2 \times \frac{f}{Z} \cos(90 + A + B)$$

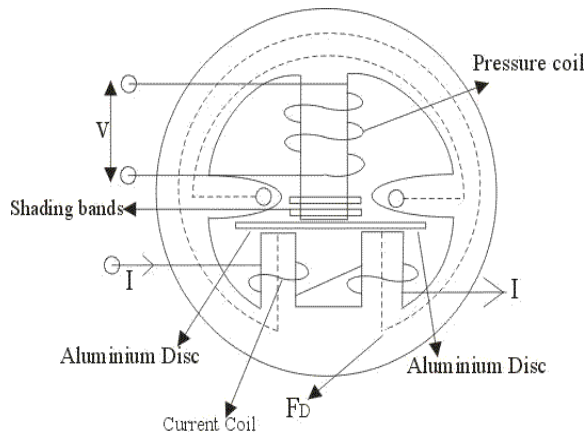

The total torque is $T_{d1} - T_{d2}$, on substituting the value of T_{d1} and T_{d2} and simplifying the expression we get

$$T_{d1} - T_{d2} = K \times F_1 \times F_2 \times \frac{f}{Z} \sin(B) \cos(A),$$

Which is known as the general expression for the deflecting torque in the **induction type meters**. Now there are two types of induction meters and they are written as follows:

- Single phase type
- Three phase type induction meters.

Here we are going to discuss about the single phase induction type in detail.

Given below is the picture of single phase induction type meter.

Single phase induction type energy meter consists of four important systems which are written as follows:

Driving System: Driving system consists of two electromagnets on which pressure coil and current coils are wound, as shown above in the diagram. The coil which consisted of load current is called current coil while coil which is in parallel with the supply voltage (i.e. voltage across the coil is same as the supply voltage) is called pressure coil. Shading bands are wound on as shown above in the diagram so as to make angle between the flux and applied voltage equal to 90 degrees. **Moving System:** In order to reduce friction to greater extent floating shaft energy meter is used, the

friction is reduced to greater extent because the rotating disc which is made up of very light material like aluminium is not in contact with any of the surface. It floats in the air. One question must arise in our mind is that how the aluminium disc floats in the air? To answer this question we need to see the constructional details of this special disc, actually it consists of small magnets on both upper and lower surfaces. The upper magnet is attracted to an electromagnet in upper bearing while the lower surface magnet also attracts towards the lower bearing magnet, hence due to these opposite forces the light rotating aluminium disc floats.

Braking System: A permanent magnet is used to produce braking torque in single phase induction energy meters which are positioned near the corner of the aluminium disc.

Counting System: Numbers marked on the meter are proportion to the revolutions made by the aluminium disc, the main function of this system is to record the number of revolutions made by the aluminium disc. Now let us look at the working operation of the single phase induction meter. In order to understand the working of this meter let us consider the diagram given below:

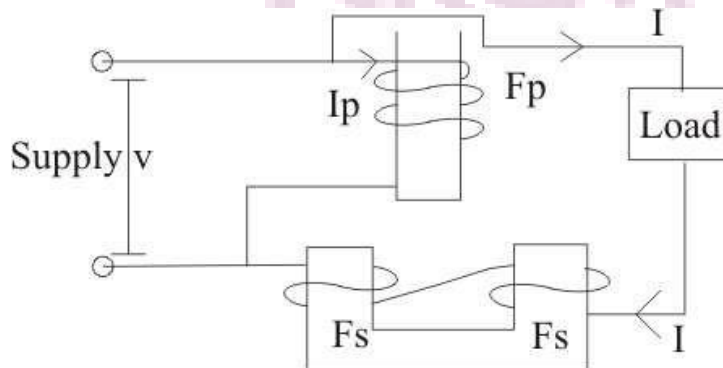

Here we have assumed that the pressure coil is highly inductive in nature and consists of very large number of turns. The current flow in the pressure coil is I_p which lags behind voltage by an angle of 90 degrees. This current produces flux F . F is divided into two parts F_g and F_p .

1. F_g which moves on the small reluctance part across the side gaps.
2. F_p : It is responsible for the production of driving torque in the aluminium disc. It moves from high reluctance path and is in phase with the current in the pressure coil. F_p is alternating in nature and thus emf E_p and current I_p . The load current which is shown in the above diagram is flowing through the current coil produces flux in the aluminium disc, and due to this alternating flux there on the metallic disc, an eddy current is produced which interacts with the flux F_p which results in production of torque. As we have two poles, thus two torques are produced which are opposite to each other. Hence from the theory of induction meter that we have discussed already above the net torque is the difference of the two torques.

Advantages of Induction Type Meters

Following are the advantages of induction type meters:

1. They are inexpensive as compared to moving iron type instruments.
2. They have high torque to weight ratio as compared to other instruments.
3. They retain their accuracy over wide range of temperature as well as loads.

THREE PHASE ENERGY METER

Introduction

It is well established that for measurement of total power or energy in a n -conductor system, it is required to use a meter with $(n-1)$ elements. The principle of single phase energy meter can as well be extended to obtain a poly-phase energy meter, in particular a three phase energy meter. Usually, a three phase energy meter is available as a 2-element meter or 3-element meter, each element being similar in construction to the single phase meter and all elements mounted on a common shaft. The torque developed by each element is summed up mechanically and the total number of revolutions made by the shaft is proportional to the total three phase energy consumption.

Construction, Operation and Testing

In a two-element, three phase energy meter the two discs are mounted on a common spindle and each disc has its own brake magnet. The moving

system drives a single gear train. Each unit is provided with its own copper shading ring, shading band, friction compensator, etc., for adjustments to be made to obtain the correct reading.

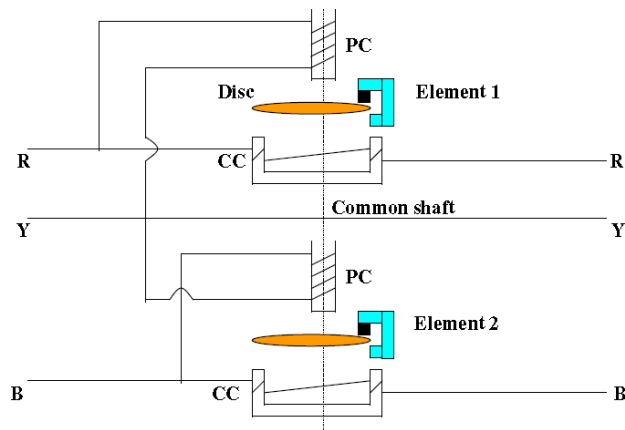

Figure 8.7 Three Phase Energy Meter

A two element energy meter used for three phase energy measurements in three phase three wire systems, is schematically shown in figure 8.7. It is needful that for the same power/ energy, the driving torque should be equal in the two elements. This is checked by torque adjustment. For torque adjustment, the two current coils are connected in series opposition and the two potential coils are connected in parallel. Full load current is allowed to pass through the current coil. This set up causes the two torques to be in opposition and so, if the torques are equal, then the disc should not move. If there is any slight motion indicating inequality of the two torques, then the magnetic shunt is adjusted until the disc stalls. Thus the torque balancing is obtained before testing the meter. The friction compensator and brake magnet positions are adjusted to each of the two/three elements separately, treating each of them as a single phase element on single phase AC supply. The calibration of three phase meter can also be performed in a similar manner, as that described earlier, for single phase energy meters.

ERRORS IN ENERGY METERS

The energy measurements by energy meters involve errors owing to many sources and reasons as follows:

1. **Errors in driving system** include errors due to incorrect magnitude of flux values, phase angles, etc. and lack of symmetry in magnetic circuit.

2 **Errors in braking system** such as changes in the strength of brake magnet, changes in disc resistance, self braking effect of series magnet flux and abnormal friction of the moving parts. 3 Errors in registering system are also expected to be present since they involve mechanical parts. They are taken care of by calibration of the meter.

4 errors caused due to friction, overloads, phase angle

variations, temperature effects, creeping of the meter, etc. These errors are avoided by correct adjustments made using the various compensator facility provided on the meter.

Adjustments

Full Load UPF Adjustment: The potential coil is connected across rated supply voltage and rated full load current at unity power factor is passed through the current coil. The brake magnet position is adjusted to vary the braking torque so that the moving system moves at correct speed.

Lag or LPF adjustment: It is clear from equation (8.10) that the energy meter will register correct value only if the angle between the shunt magnet flux, ϕ_P and the supply voltage, V is 90° ($D = 90^\circ$). Hence the pressure coil should be designed to be highly inductive. Also, various lag adjustment devices are made use of for this purpose. For LPF adjustments, the pressure coil is connected across the rated supply voltage and rated full load current at 0.5 lagging power factor is passed through the current coil. The lag device is adjusted until the meter runs at true speed.

Light Load UPF Adjustment: Firstly, full load UPF and LPF adjustments are made on the meter until it runs at correct speed. Then rated supply voltage is applied across the pressure coil and a very low current of 5-10 % of full load value is passed through the meter at unity power factor. The light load adjustment is done so that the meter runs at proper speed.

Creep Adjustment: Firstly, full load UPF and light load adjustments are made for correct speeds at both the loads and the performance is rechecked at 0.5 power factor. Then, as a final check on all the above adjustments, the pressure coil is excited by 110 % of the rated voltage with zero load current. If the light load adjustment is proper, the meter should not creep under these conditions. If the error still persists, then all the above adjustments are carried out once again

Phantom Loading

In the energy meter testing, the actual registration of energy (by the meter) is verified against known standard values at various loads and power factors. The energy meter testing helps in providing suitable adjustments in the meter so as to reduce errors. The actual registration is verified under the following test conditions.

At rated voltage, 5% of rated current and unity power factor.

At rated voltage, 125% of rated current and unity power factor.

At rated voltage, rated current, and 0.5 lagging power factor.

At rated voltage, 50% of rated current and unity power factor.

At rated voltage, 0.5% of rated current and unity power factor. This test is called starting test. Since, at this small load also, the disc should start rotating, Of course, accuracy is not the criteria in this test.

At 110% of rated voltage and open-circuited current coil. This test is called as creep test. The disc should not creep (or rotate) under this test conditions.

In order to test high capacity energy meters for the above conditions, tremendous loss of power will occur. Hence, to reduce wastage of power, phantom loading is used for testing the energy meter.

Phantom Loading :

Phantom loading is a fictitious loading that resembles the actual full-load conditions. The main advantage of testing a meter under phantom loading conditions over direct loading one is that the power or energy consumption is comparatively too small.

Phantom Loading in Energy Meter

As shown in the figure above, the pressure coil (or the shunt winding) is energized with its rated voltage and the current coil (or the series winding) is energized by a low voltage supply. The impedance of the current coil circuit is quite small. So for the rated amount of current also, the power consumption will be small. Although the impedance of the pressure coil is high, the current through it is very small.

Hence, the power consumed in the pressure coil will also be small. Therefore, the overall power or energy dissipation during the testing period will be small. For this reason, phantom loading is considered to be the most economical one for testing purposes.

Trivector meter

Trivector meter is an energy meter which accurately measures all the parameters of supply such as voltage, current, power factor, active load, reactive load, apparent load etc., now a days static electronic meters are used for commercial and industrial applications. These electronic meters use micro controllers with their own programming language.

Trivector meter gets the input supply to be measured using CT/PTs. That is current input from Current Transformers and voltage input from Potential Transformers connected in the circuit. It is a true four quadrant measuring instrument. LCD display with annunciators for showing various critical events is used.

Principle of Operation:

The principle of operation of trivector energy meter is explained with the help of block diagram.

It mainly consists of the following units.

- Energy measuring unit: voltage sampling, current sampling, measuring integrated circuit

An analogue to digital converter is used to sample voltage and current relative to incoming waveform. For getting accurate results the sampling rate should be high.

- **Data processing unit:** Micro Controller Unit [MCU], Memory storage cards

Very highly reliable Read Only Memory [ROM] is used to retain the data for so many years even if there is no power.

- **Power supply unit:** AC power supply, battery
- **Input/output unit:** LCD display, Optical communication, RJ11 port for Remote communication

Data from ROM can either be displayed on the meter LCD or communicated via an optical communication port/RJ11 port on to a hand-held Meter Reading Instrument [MRI].

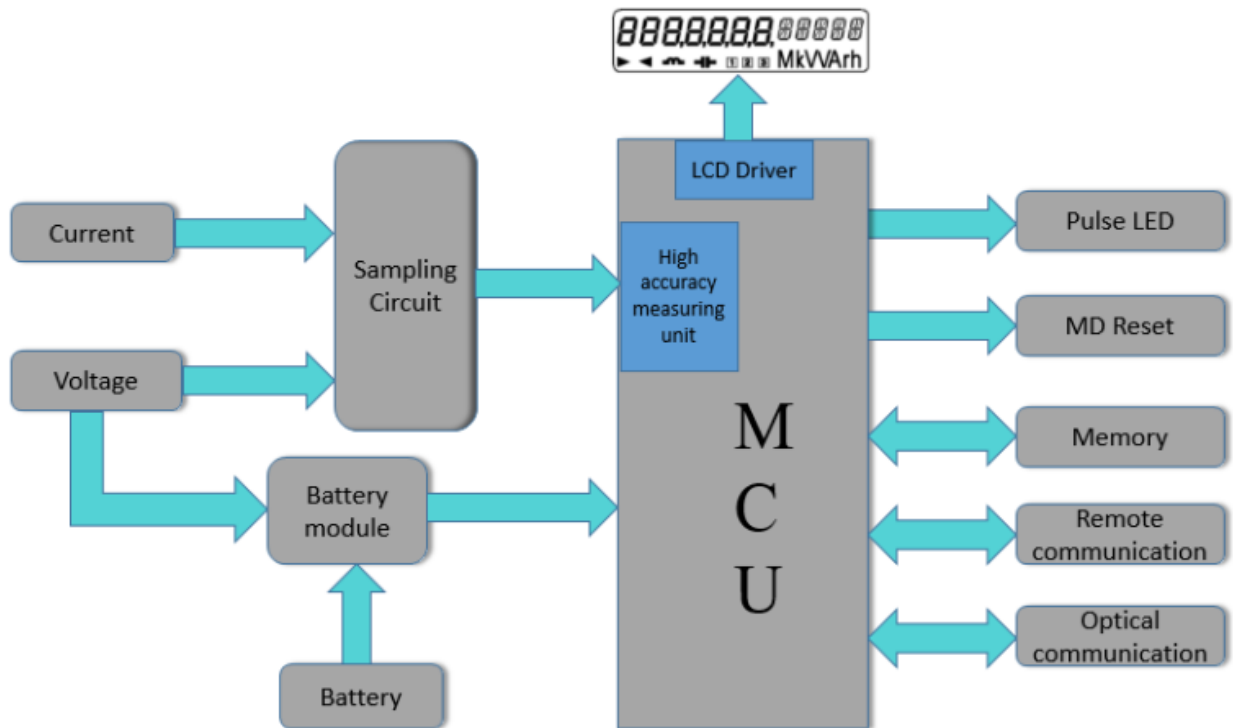

Block Diagram of Trivector Meter



www.nrcm.gov.in

UNIT – IV DC & AC BRIDGES

MEASUREMENT OF RESISTANCE

Resistance is one of the most basic elements encountered in electrical and electronics engineering. The value of resistance in engineering varies from very small value like, resistance of a transformer winding, to very high values like, insulation resistance of that same transformer winding. Although a multimeter works quite well if we need a rough value of resistance, but for accurate values and that too at very low and very high values we need specific methods. In this article we will discuss various methods of resistance measurement. For this purpose we categories the resistance into three classes-



MEASUREMENT OF LOW RESISTANCE ($<1\Omega$)

The major problem in **measurement of low resistance** values is the contact resistance or leadresistance of the measuring instruments, though being small in value is comparable to the resistance being measured and hence causes serious error

The methods employed for measurement of low resistances are:-

- Kelvin's Double Bridge Method
- Potentiometer Method
- Ducter Ohmmeter.

KELVIN'S DOUBLE BRIDGE

Kelvin's double bridge is a modification of simple Wheatstone bridge. Figure below shows the circuit diagram of Kelvin's double bridge.

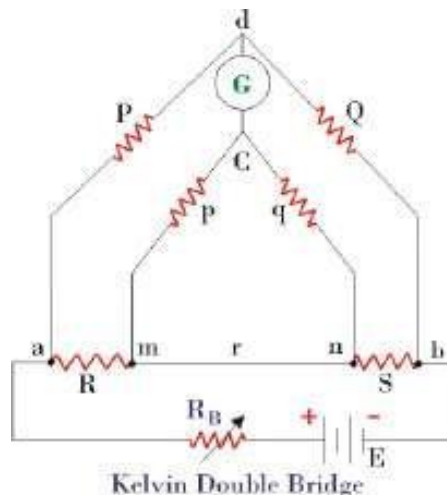

As we can see in the above figure there are two sets of arms, one with resistances P and Q and other with resistances p and q. R is the unknown low resistance and S is a standard resistance. Here r represents the contact resistance between the unknown resistance and the standard resistance, whose effect we need to eliminate. For measurement we make the ratio P/Q equal to p/q and hence a balanced Wheatstone bridge is formed leading to null deflection in the galvanometer. Hence for a balanced bridge we can write

$$\text{Or, } \left\{ \frac{P}{P+Q} \right\} E_{ab} = I \left[R + \frac{p}{p+q} \left\{ \frac{r(p+q)}{p+q+r} \right\} \right] \dots\dots(1)$$

$$\text{Where, } E_{ab} = I \left[R + S + \frac{p}{p+q} \left\{ \frac{r(p+q)}{p+q+r} \right\} \right] \dots\dots(2)$$

Putting eqn 2 in 1 and solving and using P/Q = p/q, we get-

$$R = \frac{P}{Q} S$$

Hence we see that by using balanced double arms we can eliminate the contact resistance completely and hence error due to it. To eliminate another error caused due to thermo-electric emf, we take another reading with battery connection reversed and finally take average of the two readings. This bridge is useful for resistances in range of $0.1\mu\Omega$ to 1.0Ω .

MEASUREMENT OF MEDIUM RESISTANCE (1Ω - $100k\Omega$)

Following are the methods employed for measuring a resistance whose value is in the range 1Ω - $100k\Omega$ -

- Ammeter-Voltmeter Method
- Wheatstone Bridge Method
- Substitution Method
- Carey- Foster Bridge Method
- Ohmmeter Method

WHEATSTONE BRIDGE METHOD

This is the simplest and the most basic bridge circuit used in measurement studies. It mainly consists of four arms of resistance P, Q; R and S. R is the unknown resistance under experiment, while S is a standard resistance. P and Q are known as the ratio arms. An EMF source is

connected between points a and b while a galvanometer is connected between points c and d

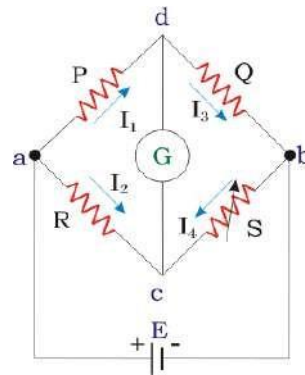

Wheatstone Bridge

A bridge circuit always works on the principle of null detection, i.e. we vary a parameter until the detector shows zero and then use a mathematical relation to determine the unknown in terms of varying parameter and other constants. Here also the standard resistance, S is varied in order to obtain null deflection in the galvanometer. This null deflection implies no current from point c to d, which implies that potential of point c and d is same. Hence

$$I_1 P = I_2 R \dots\dots (4)$$

$$\text{Also, } I_1 = I_3 = \frac{E}{(P + Q)} \text{ and } I_2 = I_4 = \frac{E}{(R + S)} \dots\dots (5)$$

Combining the above two equations we get the famous equation –

$$R = \frac{P}{Q} S$$

Carey Foster Bridge

The Carey foster bridge principle is simple and similar to Wheatstone’s bridge working principle. It works on the principle of null detection. That means the ratios of the resistances will be equal and the galvanometer records zero where there is no current flow.

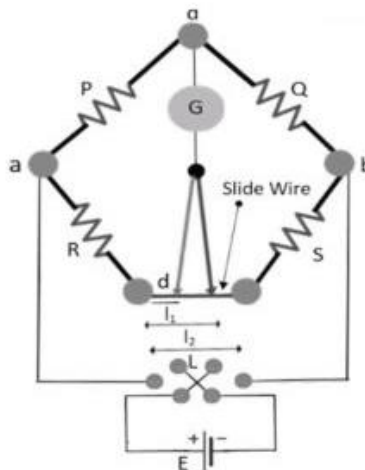

Electrical Measurements & Instrumentation (EE3101PC)

The Carey foster bridge circuit diagram is shown below. There are two units in the circuit
Bridge Unit
Testing Unit

The testing unit contains the power supply, galvanometer, and variable resistances which are to be measured. The DC supply is applied to eliminate the issues of battery discharge concerning time. So, it doesn't show any impact on the output.

From the figure, the bridge circuit is constructed with P, Q, R, and S resistances. P and Q are the known resistances used for comparison. R and S are unknown resistances to be measured. The slide wire with a length L is placed between the resistances R and S as shown in the figure. To equalize/equivalent the ratios of resistances P/Q and R/S, the values of P and Q can be adjusted. Slide the contact of the slide wire to equivalent the resistance ratio.

Consider l_1 be the distance from the left side where the bridge is balanced. Interchange the resistances R and S while the bridge gets balanced by sliding the contact with a distance of l_2 .

The switch is used to interchange the resistances R and S while testing. The galvanometer records zero when the bridge is balanced. The first bridge balance equation is,

$$P/Q = (R + l_1 r) / [(S + (L - l_1) r)]$$

Where r = resistance/unit length of the slide wire.

Now interchange the resistances R and S. Then the balanced equation for the bridge circuit is given as,

For the first balance equation, we get,

$$P/Q + 1 = [(R + l_1 r + S + (L - l_1) r) / [S + (L - l_1) r]] \dots \dots \text{Eq (1)}$$

$$P/Q = (R + S + l_1 r) / (S + (L - l_1) r)$$

We get a second bridge balance equation as

$$P/Q + 1 = [(S + l_2 r + R + (L - l_2) r) / [R + (L - l_2) r]] \dots \dots \text{Eq (2)}$$

$$P/Q + 1 = (S + R + l_2 r) / (R + (L - l_2) r)$$

From the above equations (1) and (2)

$$S + (L - l_1) r = R + (L - l_1) r$$

$$S - R = (l_1 - l_2) r$$

At the bridge balance condition, the difference between the resistances S and R is equal to the difference of distance between the lengths l_1 and l_2 of the slide wire.

Hence this type of bridge circuit is also called as Carey foster slide wire bridge circuit.

In practice, when the bridge is unbalanced, the galvanometer is connected in parallel with the low resistance, which avoids the burning of the circuit. The Carey foster bridge is sensitive where the measurement is to be done at the null point. and the known and unknown resistances are comparable.

Calibration of Slide Wire

To achieve the calibration of slide wire, place the resistances R or S in parallel with the known resistances of slide wire as shown in the figure.

For calibration of slide wire, consider S be the known resistance

S' be the resistance value when connected in parallel.

$$S - R = (l_1 - l_2) r$$

$$S' - R = (l_1' - l_2') r$$

$$(S - R) / (l_1 - l_2) = (S' - R) / (l_1' - l_2')$$

To get the value of R to solve the above equation,

$$R = [S(l_1' - l_2') - S'(l_1 - l_2)] / [(l_1' - l_2') - (l_1 - l_2)] \dots \dots \text{Eq (3)}$$

By using Carey foster bridge, the values of resistances R and S can be compared and measured directly concerning length. The resistances P, Q, and slide contact are eliminated.

Errors while Constructing Carey Bridge Circuit and Calibrating Slide Wire

The constant resistance is excessive when the edges of the connected wires, copper strips, and resistance end tips are not clean.

Tight connection of fractional resistances can develop adverse resistance contact when the current flows through the slide wire for a longer period, then the wire may get heated up and get damaged.

While sliding the length of the wire, it might be non-uniform and the cross-sectional dimension of the wire can be modified.

Advantages

The advantages of Carey foster bridge are

- The complexity of the bridge circuit is reduced because there is no need for additional equipment except the slide wire and the resistances.
- It can be utilized as the meter bridge where the slide wire length can be increased by connecting resistances in series. Hence the accuracy of the bridge circuit is increased.
- Construction is simple and easy to design
- The components used in the circuit are not complex

Applications of Carey Foster Bridge

The applications of Carey foster bridge are as follows

- It is used to calculate the values of medium resistances
- It is used to compare the approximate values of equal resistances
- It is used to measure the value of the specific resistance of the slide wire. > Used in light detector circuits.
- Used to measure the intensity of light, pressure, or strain. Since it is a modified form of Wheatstone's bridge

MEASUREMENT OF HIGH RESISTANCE (>100KΩ)

Following are few methods used for measurement of high resistance values-

- Loss of Charge Method
- Megger
- Megohm bridge Method
- Direct Deflection Method

LOSS OF CHARGE METHOD
In this method we utilize the equation of voltage across a discharging capacitor to find the value of unknown resistance R. Figure below shows

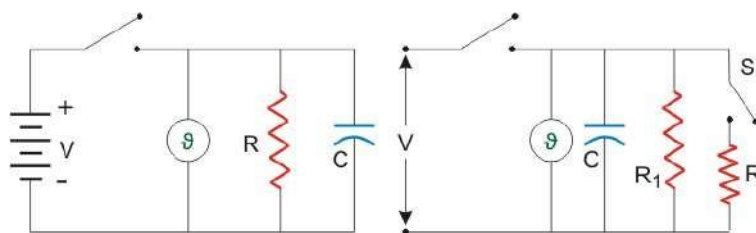

Loss of Charge Method

are-

$$v = Ve^{-\frac{t}{RC}}$$
$$R = \frac{0.4343t}{C \log_{10} V/v}$$

However the above case assumes no leakage resistance of the capacitor. Hence to account for it we use the circuit shown in the figure below. R_1 is the leakage resistance of C and R is the unknown resistance. We follow the same procedure but first with switch S_1 closed and next with switch S_1 open. For the first case we

$$R' = \frac{0.4343t}{C \log_{10} V/v}$$

$$\text{Where, } R' = \frac{RR_1}{R + R_1}$$

get

For second case with switch open we get

$$R_1 = \frac{0.4343t}{C \log_{10} V/v}$$

Using R_1 from above equation in equation for R' we can find R.

AC BRIDGES

General form of A.C. bridge

AC bridge are similar to D.C. bridge in topology (way of connecting). It consists of four arms AB, BC, CD and DA. Generally the impedance to be measured is connected between 'A' and 'B'. A detector is connected between 'B' and 'D'. The detector is used as null deflection instrument. Some of the arms are variable element. By varying these elements, the potential values at 'B' and 'D' can be made equal. This is called balancing of the bridge.

Electrical Measurements & Instrumentation (EE3101PC)

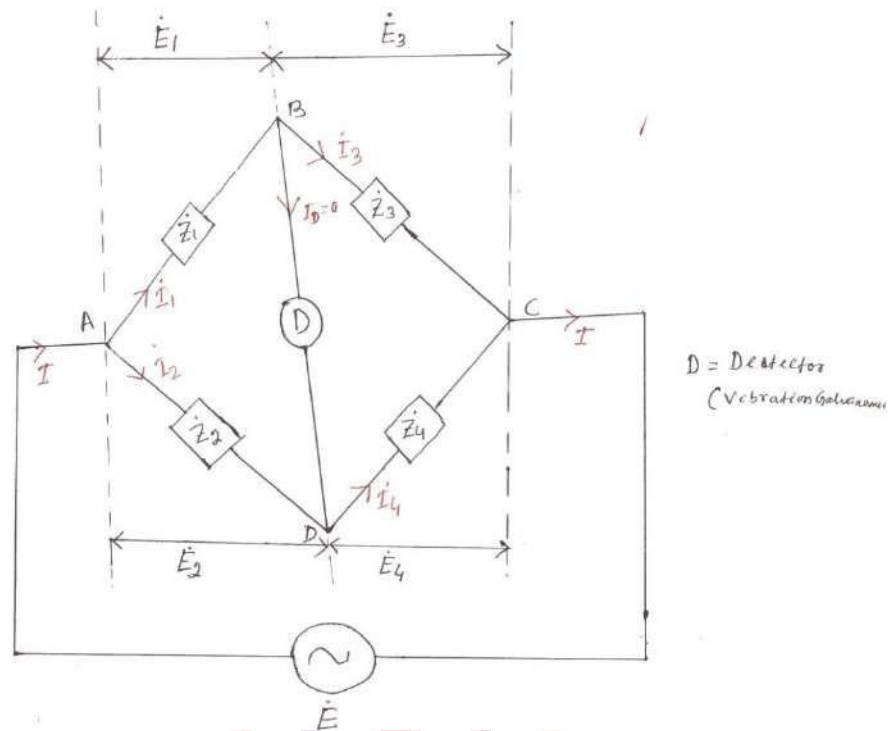

Fig. 2.1 General form of A.C.

bridge. At the balance condition, the current through detector is zero.

$$\therefore I_1 = I_3$$

$$I_2 = I_4$$

$$\therefore \frac{I_1}{I_2} = \frac{I_3}{I_4}$$

Electrical Measurements & Instrumentation (EE3101PC)

At balance condition,

Voltage drop across 'AB'=voltage drop across 'AD'.

$$\dot{E}_1 = \dot{E}_2$$

$$\therefore \dot{I}_1 \dot{Z}_1 = \dot{I}_2 \dot{Z}_2$$

Similarly, Voltage drop across 'BC'=voltage drop across 'DC'

$$\dot{E}_3 = \dot{E}_4$$

$$\therefore \dot{I}_3 \dot{Z}_3 = \dot{I}_4 \dot{Z}_4$$

From Eqn. (2.2), we have $\therefore \frac{\dot{I}_1}{\dot{I}_2} = \frac{\dot{Z}_2}{\dot{Z}_1}$

From Eqn. (2.3), we have $\therefore \frac{\dot{I}_3}{\dot{I}_4} = \frac{\dot{Z}_4}{\dot{Z}_3}$

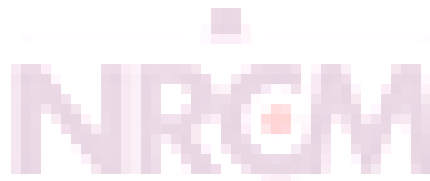

www.nirgm.ac.in

Electrical Measurements & Instrumentation (EE3101PC)

From equation -2.1, it can be seen that, equation -2.4 and equation-2.5 are equal.

$$\therefore \frac{\dot{Z}_2}{\dot{Z}_1} = \frac{\dot{Z}_4}{\dot{Z}_3}$$

$$\therefore \dot{Z}_1 \dot{Z}_4 = \dot{Z}_2 \dot{Z}_3$$

Products of impedances of opposite arms are equal.

$$\therefore |Z_1| \angle \theta_1 |Z_4| \angle \theta_4 = |Z_2| \angle \theta_2 |Z_3| \angle \theta_3$$

$$\Rightarrow |Z_1| |Z_4| \angle \theta_1 + \theta_4 = |Z_2| |Z_3| \angle \theta_2 + \theta_3$$

$$|Z_1| |Z_4| = |Z_2| |Z_3|$$

$$\theta_1 + \theta_4 = \theta_2 + \theta_3$$



- * For balance condition, magnitude on either side must be equal.
- * Angle on either side must be equal.

Summary

For balance condition,

- $I_1 = I_3, I_2 = I_4$
- $Z_1 Z_4 = Z_2 Z_3$
- $\theta_1 + \theta_4 = \theta_2 + \theta_3$
- $E_1 = E_2$ & $E_3 = E_4$

Types of detector

The following types of instruments are used as detector in A.C. bridge.

- Vibration galvanometer
- Head phones (speaker)
- Tuned amplifier

Vibration galvanometer

Between the point 'B' and 'D' a vibration galvanometer is connected to indicate the bridge balance condition. This A.C. galvanometer which works on the principle of resonance. The A.C. galvanometer shows a dot, if the bridge is unbalanced.

Headphones

Two speakers are connected in parallel in this system. If the bridge is unbalanced, the speaker produced more sound energy. If the bridge is balanced, the speaker do not produced any sound energy.

Tuned amplifier

If the bridge is unbalanced the output of tuned amplifier is high. If the bridge is balanced, output of amplifier is zero.

Measurements of inductance

Maxwell's inductance bridge

The choke for which R_1 and L_1 have to measure connected between the points 'A' and 'B'. In this method the unknown inductance is measured by comparing it with the standard inductance.

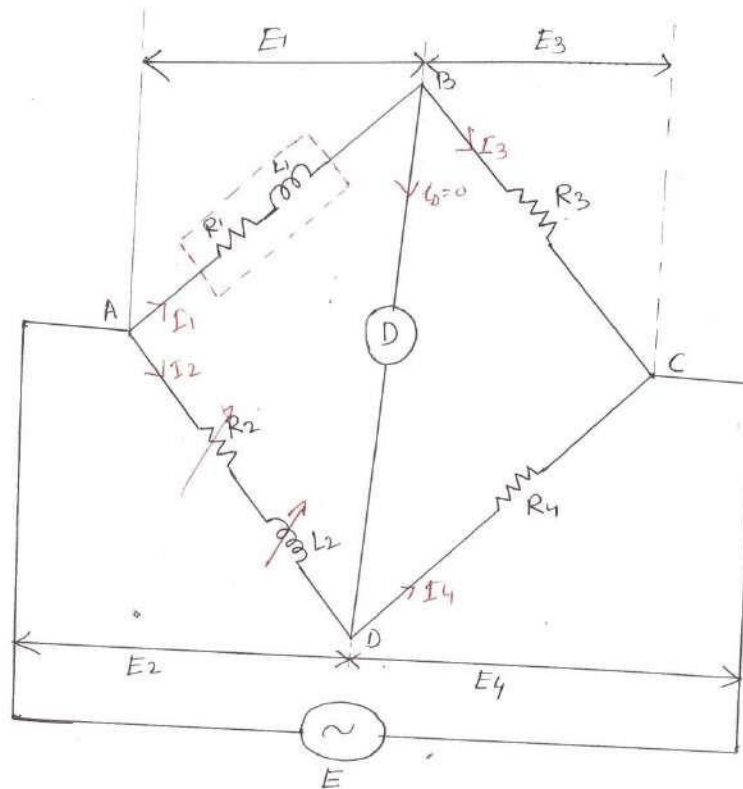

Fig. 2.2 Maxwell's inductance

bridge L_2 is adjusted, until the detector indicates zero current.

Let R_1 = unknown resistance

L_1 = unknown inductance of the choke.

L_2 = known standard inductance

R_1, R_2, R_4 = known resistances.

Electrical Measurements & Instrumentation (EE3101PC)

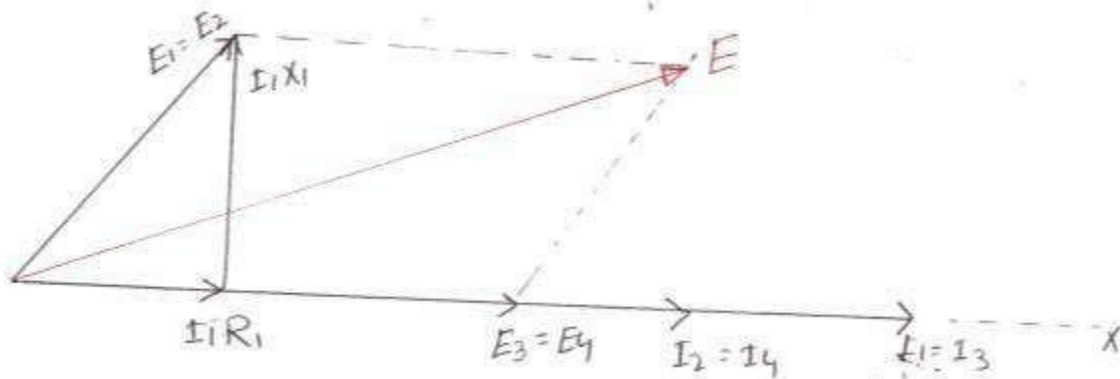

Fig 2.3 Phasor diagram of Maxwell's inductance bridge

At balance condition, $\dot{Z}_1 \dot{Z}_4 = \dot{Z}_2 \dot{Z}_3$

$$(R_1 + jXL_1)R_4 = (R_2 + jXL_2)R_3$$

$$(R_1 + j\omega L_1)R_4 = (R_2 + j\omega L_2)R_3$$

$$R_1R_4 + j\omega L_1R_4 = R_2R_3 + j\omega L_2R_3$$

Comparing real part,

$$R_1R_4 = R_2R_3$$

$$\therefore R_1 = \frac{R_2R_3}{R_4}$$

Comparing the imaginary parts,

$$\omega L_1R_4 = \omega L_2R_3$$

$$L_1 = \frac{L_2R_3}{R_4}$$

$$Q\text{-factor of choke, } Q = \frac{WL_1}{R_1} = \frac{WL_2 R_3 R_4}{R_4 R_2 R_3}$$

$$Q = \frac{WL_2}{R_2}$$

Advantages

- ✓ Expression for R_1 and L_1 are simple.
- ✓ Equations are simple
- ✓ They do not depend on the frequency (as w is cancelled)
- ✓ R_1 and L_1 are independent of each other.

Disadvantages

- ✓ Variable inductor is costly.
- ✓ Variable inductor is bulky.

Maxwell's inductance capacitance bridge

Unknown inductance is measured by comparing it with standard capacitance. In this bridge, balance condition is achieved by varying ' C_4 '.

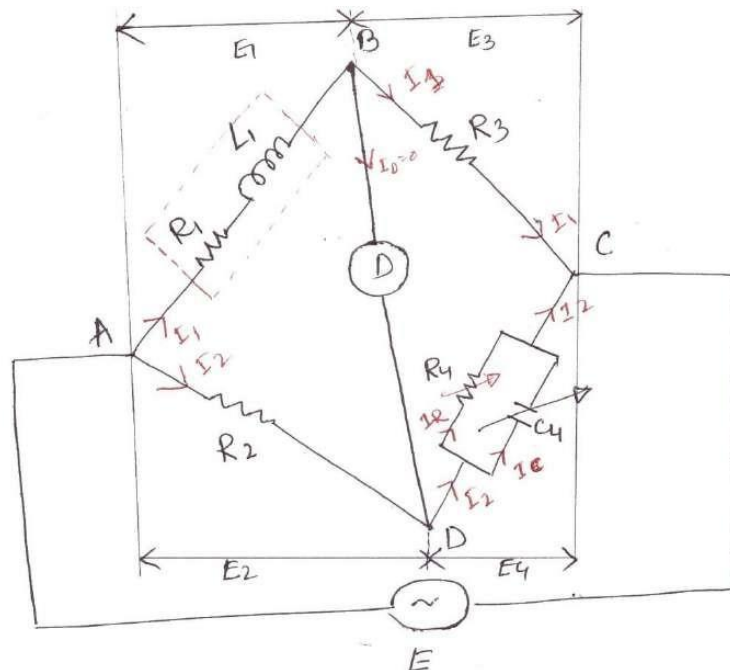

Fig 2.4 Maxwell's inductance capacitance bridge

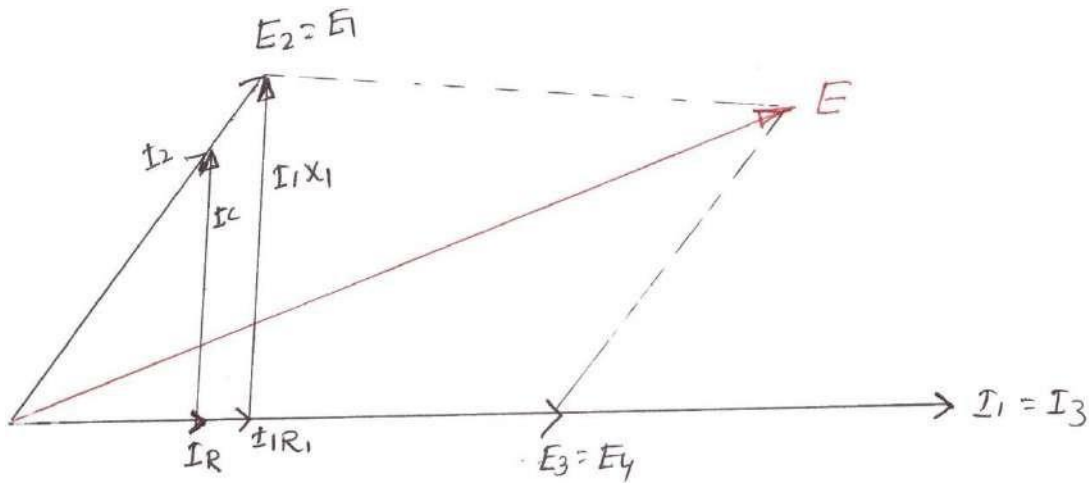

Fig 2.5 Phasor diagram of Maxwell's inductance capacitance

bridge

$$\text{At balance condition, } Z_1 Z_4 = Z_3 Z_2 \tag{2.9}$$

$$Z_4 = R_4 \parallel \frac{1}{j\omega C_4} = \frac{R_4 \times \frac{1}{j\omega C_4}}{R_4 + \frac{1}{j\omega C_4}}$$

$$Z_4 = \frac{R_4}{j\omega R_4 C_4 + 1} = \frac{R_4}{1 + j\omega R_4 C_4} \tag{2.10}$$

∴ Substituting the value of Z_4 from eqn. (2.10) in eqn. (2.9) we get

$$(R_1 + j\omega L_1) \times \frac{R_4}{1 + j\omega R_4 C_4} = R_2 R_3$$

$$(R_1 + j\omega L_1)R_4 = R_2R_3(1 + j\omega R_4C_4)$$

$$R_1R_4 + j\omega L_1R_4 = R_2R_3 + j\omega C_4R_4R_2R_3$$

Comparing real parts,

$$R_1R_4 = R_2R_3$$

$$\Rightarrow R_1 = \frac{R_2R_3}{R_4}$$

Comparing imaginary part,

$$\omega L_1R_4 = \omega C_4R_4R_2R_3$$

$$L_1 = C_4R_2R_3$$

Q-factor of choke,

$$Q = \frac{\omega L_1}{R_1} = \omega \times C_4R_2R_3 \times \frac{R_4}{R_2R_3}$$

$$Q = \omega C_4R_4$$

Advantages

- ✓ Equation of L_1 and R_1 are simple.
- ✓ They are independent of frequency.
- ✓ They are independent of each other.
- ✓ Standard capacitor is much smaller in size than standard inductor.

Disadvantages

- ✓ Standard variable capacitance is costly.
- ✓ It can be used for measurements of Q-factor in the ranges of 1 to 10.
- ✓ It cannot be used for measurements of choke with Q-factors more than 10.

We know that $Q = \omega C_4R_4$

For measuring chokes with higher value of Q-factor, the value of C_4 and R_4 should be higher. Higher values of standard resistance are very expensive. Therefore this bridge cannot be used for higher value of Q-factor measurements.

Hay's bridge

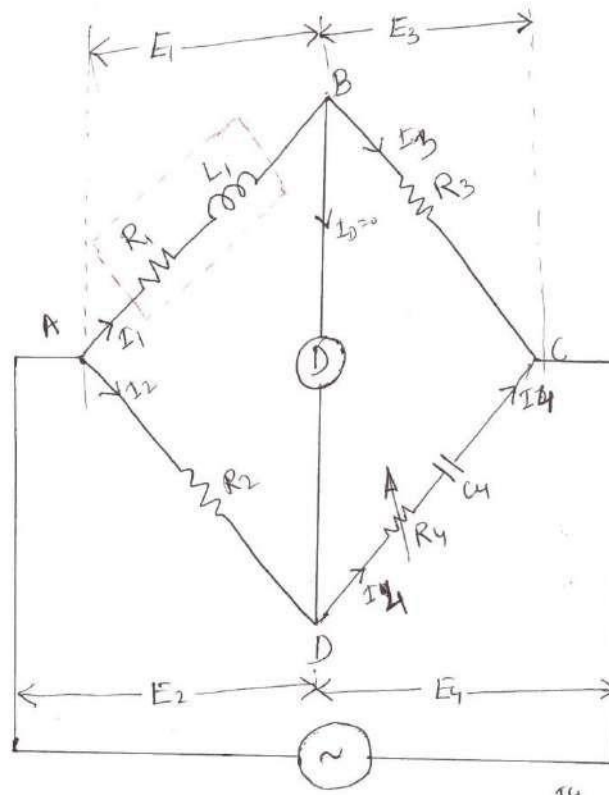

Fig 2.6 Hay's bridge

$$\dot{E}_1 = I_1 R_1 + jI_1 X_1$$

$$\dot{E} = \dot{E}_1 + \dot{E}_3$$

$$\dot{E}_4 = I_4 R_4 + \frac{I_4}{j\omega C_4}$$

$$\dot{E}_3 = I_3 R_3$$

$$Z_4 = R_4 + \frac{1}{j\omega C_4} = \frac{1 + j\omega R_4 C_4}{j\omega C_4}$$

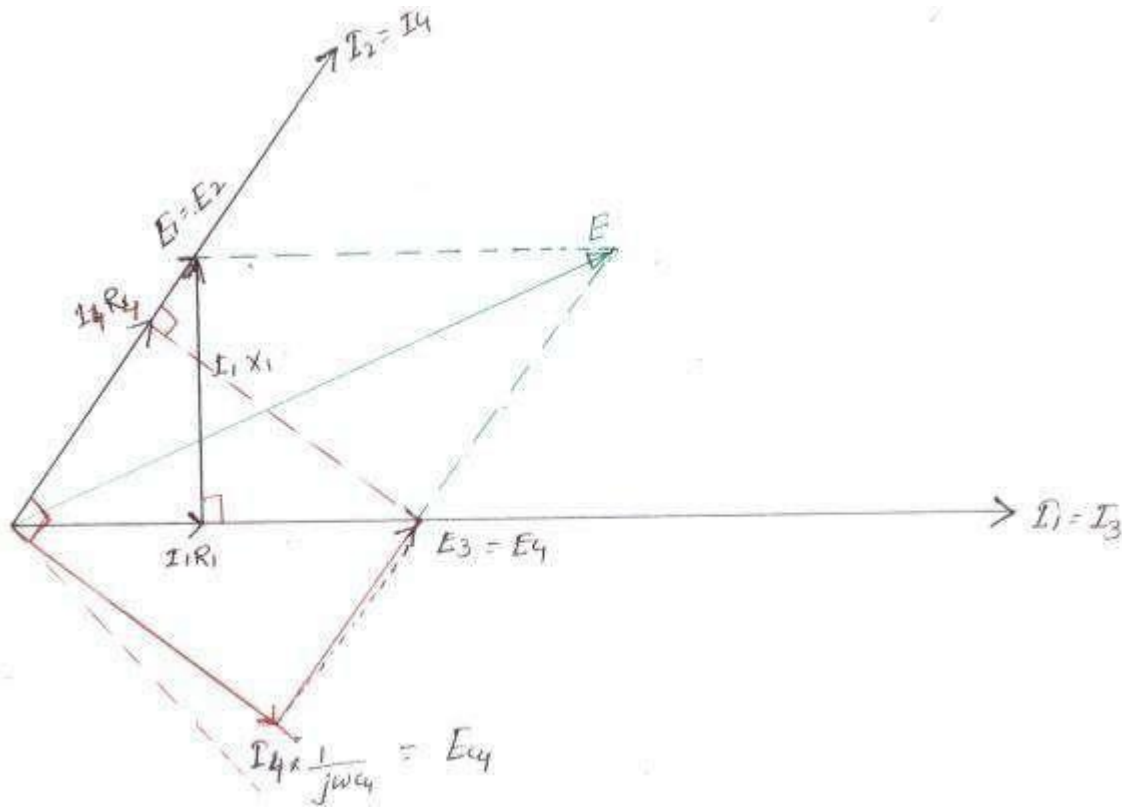

Fig 2.7 Phasor diagram of Hay's bridge

At balance condition, $Z_1 Z_4 = Z_3 Z_2$

$$(R_1 + j\omega L_1) \left(\frac{1 + j\omega R_4 C_4}{j\omega C_4} \right) = R_2 R_3$$

$$(R_1 + j\omega L_1)(1 + j\omega R_4 C_4) = j\omega R_2 C_4 R_3$$

$$R_1 + j\omega C_4 R_4 R_1 + j\omega L_1 + j^2 \omega^2 L_1 C_4 R_4 = j\omega C_4 R_2 R_3$$

$$(R_1 - \omega^2 L_1 C_4 R_4) + j(\omega C_4 R_4 R_1 + \omega L_1) = j\omega C_4 R_2 R_3$$

Comparing the real term,

$$R_1 - \omega^2 L_1 C_4 R_4 = 0$$

$$R_1 = \omega^2 L_1 C_4 R_4 \tag{2.14}$$

Comparing the imaginary terms,

$$wC_4R_4R_1 + wL_1 = wC_4R_2R_3$$

$$C_4R_4R_1 + L_1 = C_4R_2R_3$$

$$L_1 = C_4R_2R_3 - C_4R_4R_1 \tag{2.15}$$

Substituting the value of R_1 from eqn. 2.14 into eqn. 2.15, we have,

$$L_1 = C_4R_2R_3 - C_4R_4 \times w^2$$

$$L_1C_4R_4L_1 = C_4R_2R_3 - w^2L$$

$$C^2R^2$$



$$L_1 = \frac{C_4R_2R_3}{1 + w^2L_1C_4^2R_4^2} \tag{2.16}$$

Substituting the value of L_1 in eqn. 2.14, we have

$$R_1 = \frac{w^2C_4^2R_2R_3R_4}{1 + w^2C_4^2R_4^2} \tag{2.17}$$

$$Q = \frac{wL_1}{R_1} = \frac{w \times C_4R_2R_3}{1 + w^2C_4^2R_4^2} \times \frac{1 + w^2C_4^2R_4^2}{w^2C_4^2R_4R_2R_3}$$

$$Q = \frac{1}{wC_4R_4} \tag{2.18}$$

Advantages

- ✓ Fixed capacitor is cheaper than variable capacitor.
- ✓ This bridge is best suitable for measuring high value of Q-factor.

Disadvantages

- ✓ Equations of L_1 and R_1 are complicated.

- ✓ Measurements of R_1 and L_1 require the value of frequency.
- ✓ This bridge cannot be used for measuring low Q-factor.

Owen's bridge

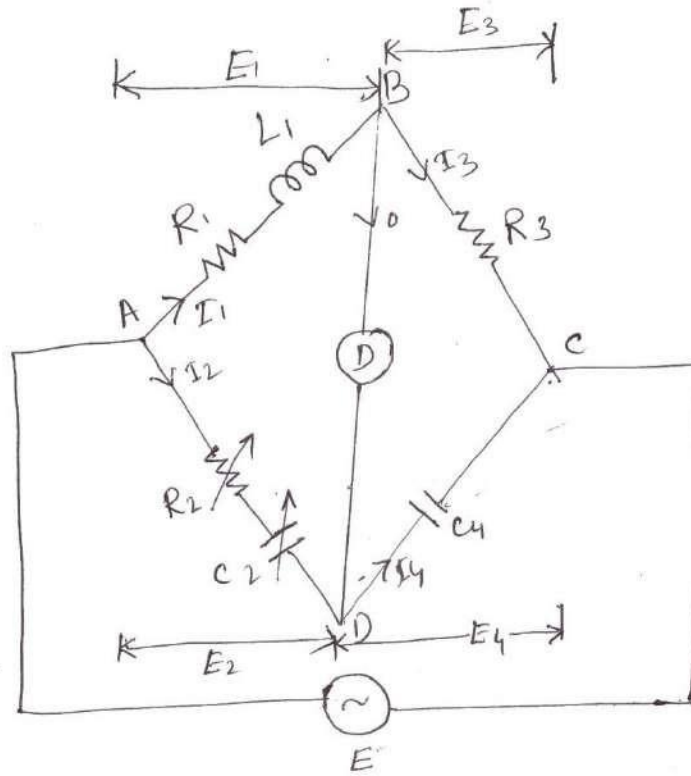

Fig 2.8 Owen's bridge

- $E_1 = I_1 R_1 + j I_1 X_1$
- I_4 leads E_4 by 90°

$$\text{➤ } \dot{E} = \dot{E}_1 + \dot{E}_3$$

$$\text{➤ } \dot{E}_2 = I_2 R_2 + \frac{I_2}{j\omega C_2}$$

Electrical Measurements & Instrumentation (EE3101PC)

Balance condition, $Z_1 Z_4 = Z_2 Z_3$

$$Z_2 = R_2 + \frac{1}{j\omega C_2} = \frac{j\omega C_2 R_2 + 1}{j\omega C_2}$$

$$\therefore (R_1 + j\omega L_1) \times \frac{1}{j\omega C_4} = \frac{(1 + j\omega R_2 C_2) \times R_3}{j\omega C_2}$$

$$C_2(R_1 + j\omega L_1) = R_3 C_4(1 + j\omega R_2 C_2)$$

$$R_1 C_2 + j\omega L_1 C_2 = R_3 C_4 + j\omega R_2 C_2 R_3 C_4$$

Comparing real terms,

$$R_1 C_2 = R_3 C_4$$

$$R_1 = \frac{R_3 C_4}{C_2}$$

Comparing imaginary terms,

$$\omega L_1 C_2 = \omega R_2 C_2 R_3 C_4$$

$$L_1 = R_2 R_3 C_4$$

$$Q\text{-factor} = \frac{\omega L_1}{R_1} = \frac{\omega R_2 R_3 C_4 C_2}{R_3 C_4}$$

$$Q = \omega R_2 C_2$$

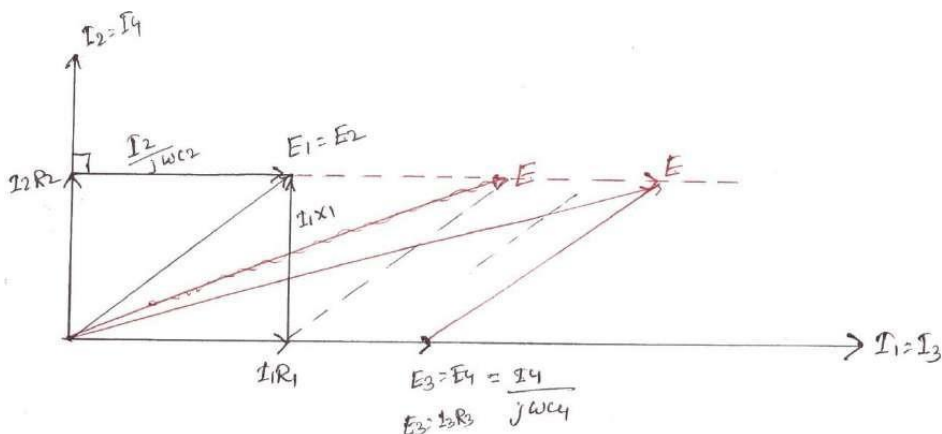

Electrical Measurements & Instrumentation (EE3101PC)

Fig 2.9 Phasor diagram of Owen's bridge



Advantages

- ✓ Expression for R_1 and L_1 are simple.
- ✓ R_1 and L_1 are independent of Frequency.

Disadvantages

- ✓ The Circuits used two capacitors.
- ✓ Variable capacitor is costly.
- ✓ Q-factor range is restricted.



Anderson's bridge

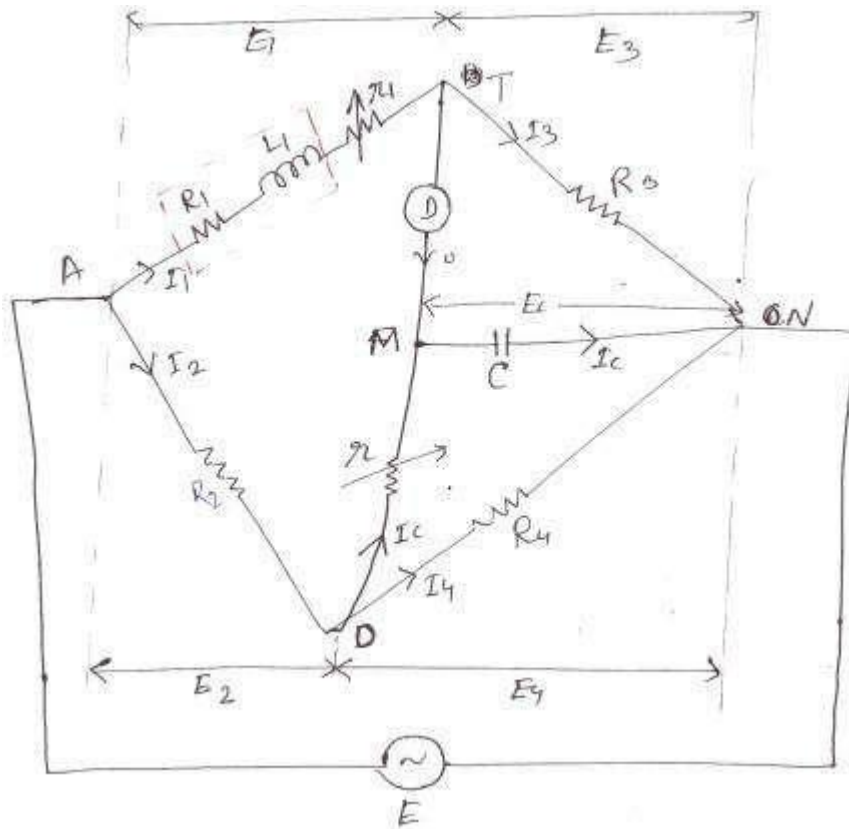

NRCM

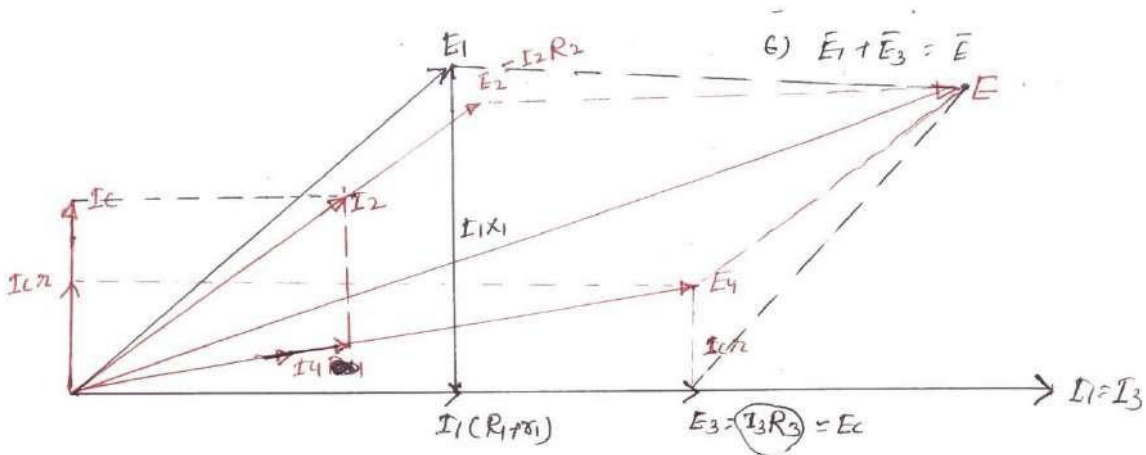

Fig 2.11 Phasor diagram of Anderson's bridge

- $\dot{E}_1 = I_1(R_1 + r_1) + jI_1X_1$
- $E_3 = E_C$
- $\dot{E}_4 = I_C r + E_C$
- $I_2 = I_4 + I_C$
- $\bar{E}_2 + \bar{E}_4 = \bar{E}$
- $\bar{E}_1 + \bar{E}_3 = \bar{E}$

Step-1 Take I_1 as reference vector. Draw $I_1R_1^1$ in phase with I_1

$$R_1^1 = (R_1 + r_1), I_1X_1 \text{ is } \perp_r \text{ to } I_1R_1^1$$

$$E_1 = I_1R_1^1 + jI_1X_1$$

Step-2 $I_1 = I_3$, E_3 is in phase with I_3 , From the circuit,

$$E_3 = E_C, I_C \text{ leads } E_C \text{ by } 90^\circ$$

Step-3 $E_4 = I_C r + E_C$

Step-4 Draw I_4 in phase with E_4 , By KCL, $\bar{I}_2 = \bar{I}_4 + \bar{I}_C$

Step-5 Draw E_2 in phase with I_2

Step-6 By KVL, $\bar{E}_1 + \bar{E}_3 = \bar{E}$ or $\bar{E}_2 + \bar{E}_4 = \bar{E}$

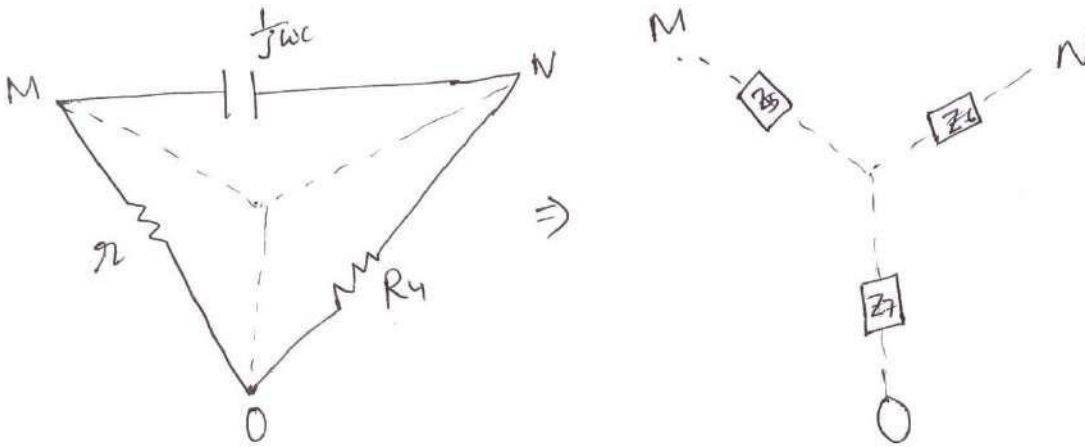

Fig 2.12 Equivalent delta to star conversion for the loop MON

$$Z_7 = \frac{R_4 \times r}{R_4 + r + \frac{1}{j\omega C}} = \frac{j\omega C R_4 r}{1 + j\omega C(R_4 + r)}$$

$$Z_6 = \frac{R_4 \times \frac{1}{j\omega C}}{R_4 + r + \frac{1}{j\omega C}} = \frac{R_4}{1 + j\omega C(R_4 + r)}$$

$$(R_1 + j\omega L_1) \times \frac{R_4}{1 + j\omega C(R_4 + r)} = R_3 \left(R_2 + \frac{j\omega C R_4 r}{1 + j\omega C(R_4 + r)} \right)$$

$$\Rightarrow \frac{(R_1 + j\omega L_1) R_4}{1 + j\omega C(R_4 + r)} = R_3 \left[\frac{R_2(1 + j\omega C(R_4 + r)) + j\omega C r R_4}{1 + j\omega C(R_4 + r)} \right]$$

$$\Rightarrow R_1 R_4 + j\omega L_1 R_4 = R_2 R_3 + j\omega C R_2 R_3 (r + R_4) + j\omega C r R_4 R_3$$

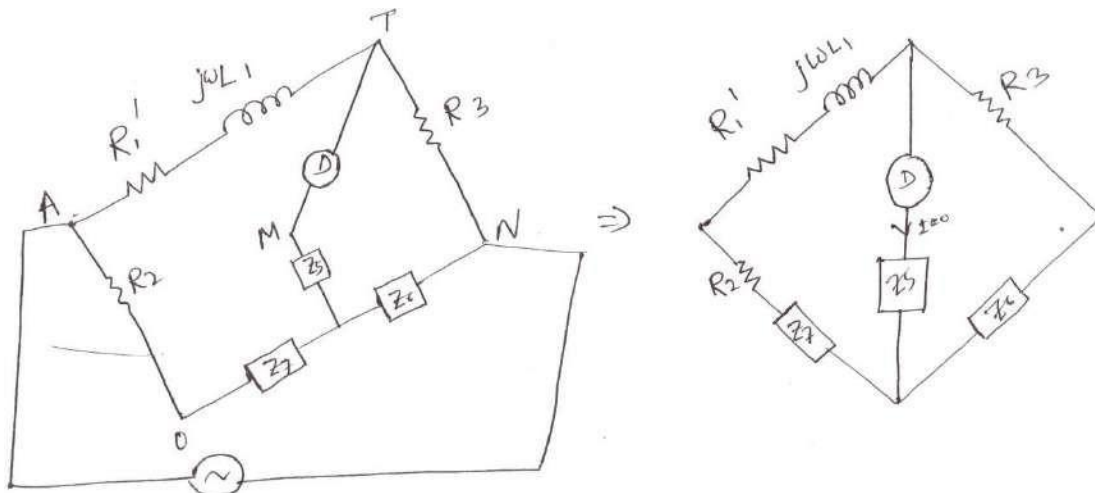

Fig 2.13 Simplified diagram of Anderson's bridge

Comparing real term,

$$R_1^1 R_4 = R_2 R_3$$

$$(R_1 + r_1) R_4 = R_2 R_3$$

$$R_1 = \frac{R_2 R_3}{R_4} - r_1$$

Comparing the imaginary term,

$$\omega L_1 R_4 = \omega C R_2 R_3 (r + R_4) + \omega C r R_3 R_4$$

$$L_1 = \frac{R_2 R_3 C}{R_4} (r + R_4) + R_3 r C$$

$$L_1 = R_3 C \left[\frac{R_2}{R_4} (r + R_4) + r \right]$$

Advantages

- ✓ Variable capacitor is not required.
- ✓ Inductance can be measured accurately.
- ✓ R_1 and L_1 are independent of frequency.
- ✓ Accuracy is better than other bridges.

Disadvantages

- ✓ Expression for R_1 and L_1 are complicated.
- ✓ This is not in the standard form A.C. bridge.

Measurement of capacitance and loss angle.

(Dissipation factor) Dissipation factors (D)

A practical capacitor is represented as the series combination of small resistance and ideal capacitance.

From the vector diagram, it can be seen that the angle between voltage and current is slightly less than 90° . The angle ' δ ' is called loss angle.

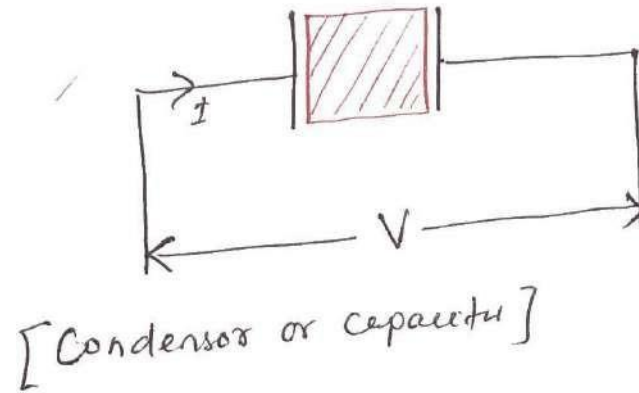

Fig 2.14 Condensor or capacitor

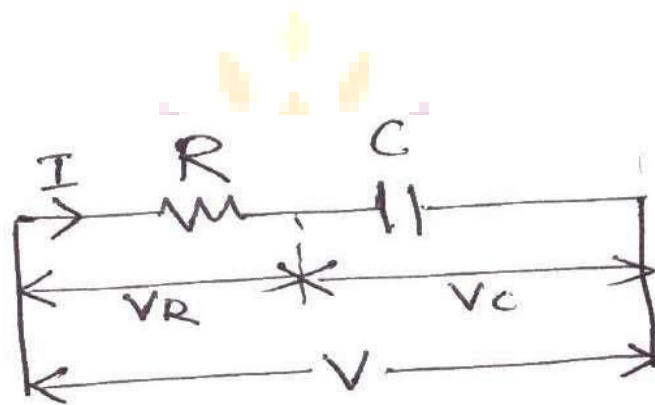

Fig 2.15 Representation of a practical capacitor

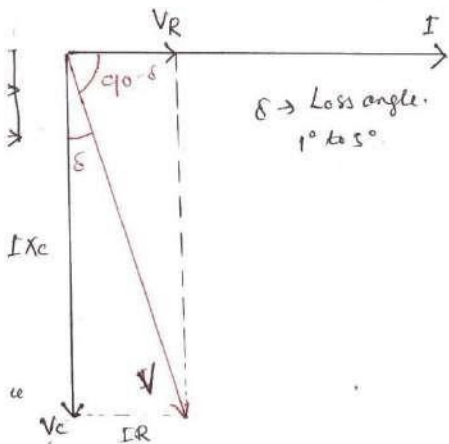

Fig 2.16 Vector diagram for a practical capacitor

Electrical Measurements & Instrumentation (EE3101PC)

A dissipation factor is defined as ' $\tan \delta$ '.

$$\therefore \tan \delta = \frac{IR}{IX_C} = \frac{R}{X_C} = \omega CR$$

$$D = \omega CR$$

$$D = \frac{1}{Q}$$

$$D = \tan \delta = \frac{\sin \delta}{\cos \delta} \cong \frac{\delta}{1} \quad \text{For small value of '}\delta\text{' in radians}$$

$$D \cong \delta \cong \text{Loss Angle} \quad (\delta \text{ must be in radian)}$$

Desauty's Bridge



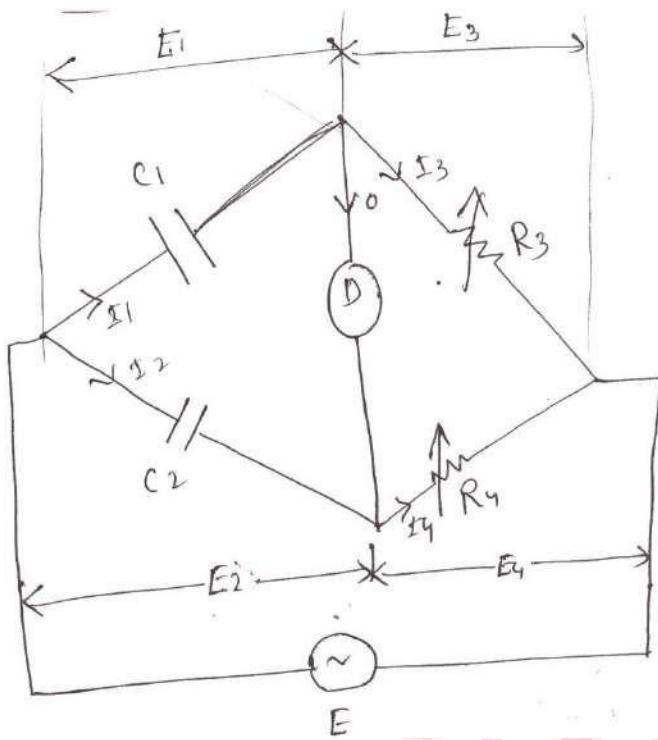

Fig 2.17 Desauty's bridge

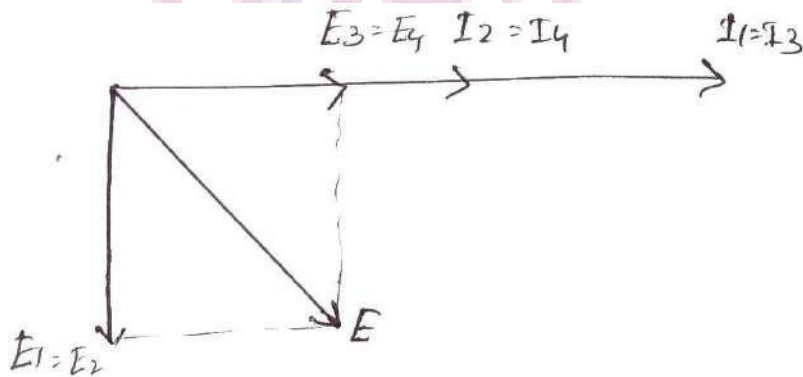

Fig 2.18 Phasor diagram of Desauty's bridge

Modified desauty's sbridge

$C_1 =$ Unknown capacitance

At balance condition,

$$\frac{1}{j\omega C_1} \times R_4 = \frac{1}{j\omega C_2} \times R_3$$

$$\frac{R_4}{C_1} = \frac{R_3}{C_2}$$

$$\Rightarrow C_1 = \frac{R_4 C_2}{R_3}$$

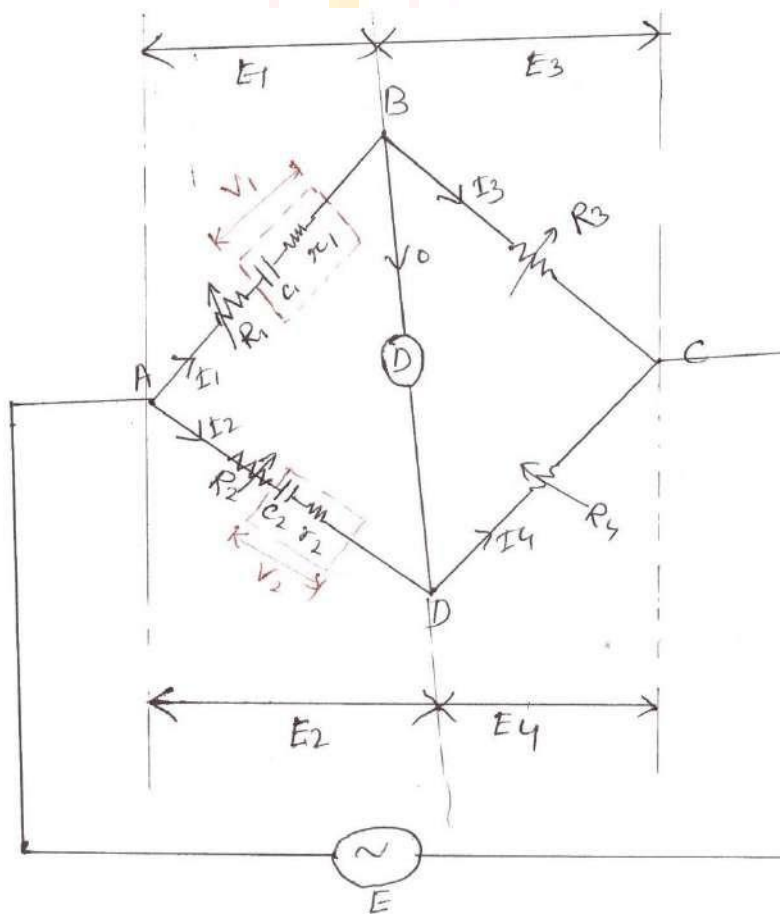

Fig 2.19 Modified Desauty's bridge

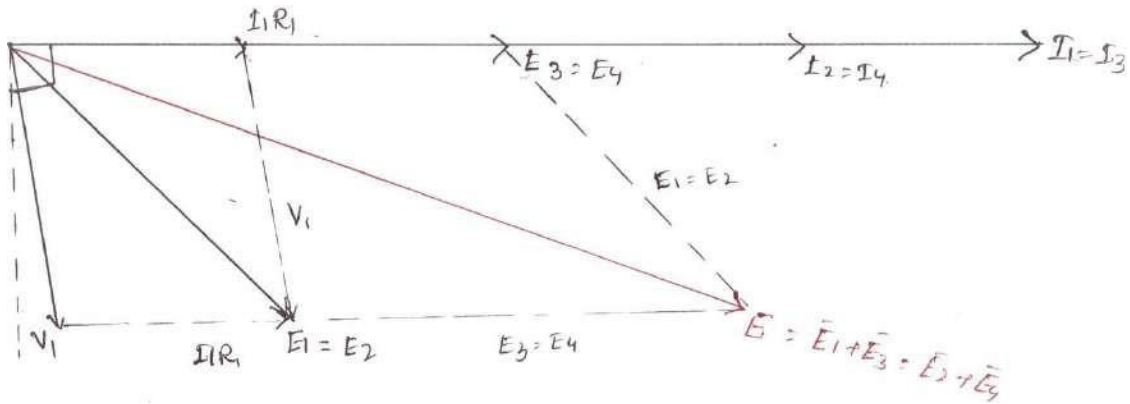

Fig 2.20 Phasor diagram of Modified Desauty's bridge

$$R_1^1 = (R_1 + r_1)$$

$$R_2^1 = (R_2 + r_2)$$

At balance condition, $(R_1^1 + \frac{1}{j\omega C_1})R_4 = R_3(R_2^1 + \frac{1}{j\omega C_2})$

$$R_1^1 R_4 + \frac{R_4}{j\omega C_1} = R_3 R_2^1 + \frac{R_3}{j\omega C_2}$$

Comparing the real term, $R_1^1 R_4 = R_3 R_2^1$

$$R_1^1 = \frac{R_3 R_2^1}{R_4}$$

$$R + r_1 = \frac{(R_2 + r_2) R_3}{R_4}$$

Comparing imaginary term,

$$\frac{R_4}{\omega C_1} = \frac{R_3}{\omega C_2}$$

$$C_1 = \frac{R_4 C_2}{R_3}$$

Dissipation factor $D = \omega C_1 r_1$

Advantages

- ✓ r_1 and c_1 are independent of frequency.
- ✓ They are independent of each other.
- ✓ Source need not be pure sinewave.

Scheringbridge

$$E_1 = I_1 r_1 - j I_1 X_4$$

$C_2 = C_4 =$ Standard capacitor (Internal

resistance=0) $C_4 =$ Variable capacitance.

$C_1 =$ Unknown capacitance.

$r_1 =$ Unknown series equivalent resistance of the capacitor.

$R_3 = R_4 =$ Known resistor.

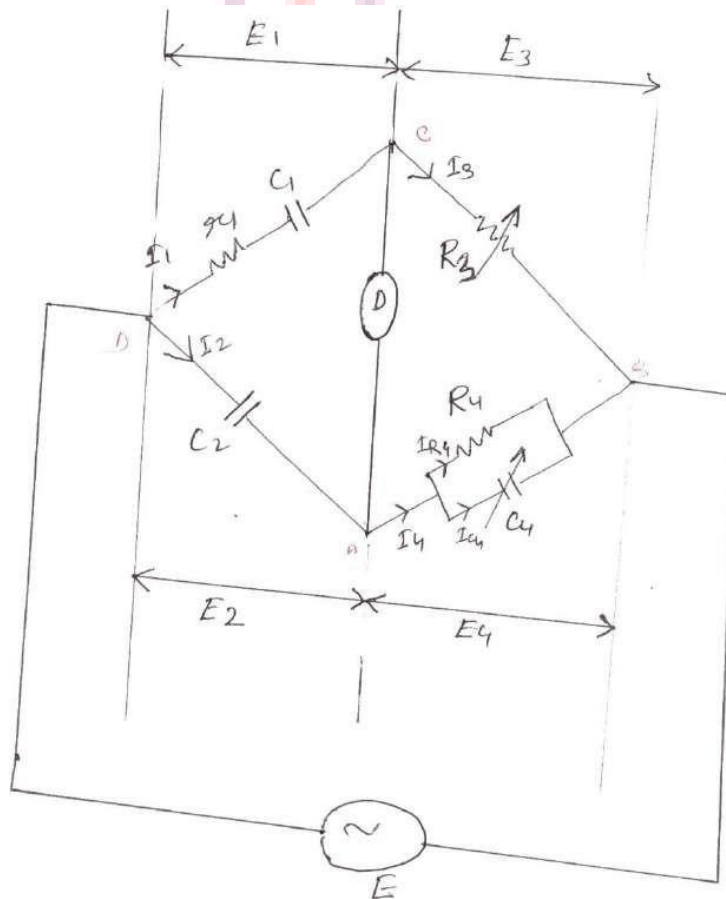

Fig 2.21 Schering bridge

$$Z_1 = r_1 + \frac{1}{j\omega C_1} = \frac{j\omega C_1 r_1 + 1}{j\omega C_1}$$

$$Z_4 = \frac{R_4 \times \frac{1}{j\omega C_4}}{R_4 + \frac{1}{j\omega C_4}} = \frac{R_4}{1 + j\omega C_4 R_4}$$



www.nrcm.ac.in

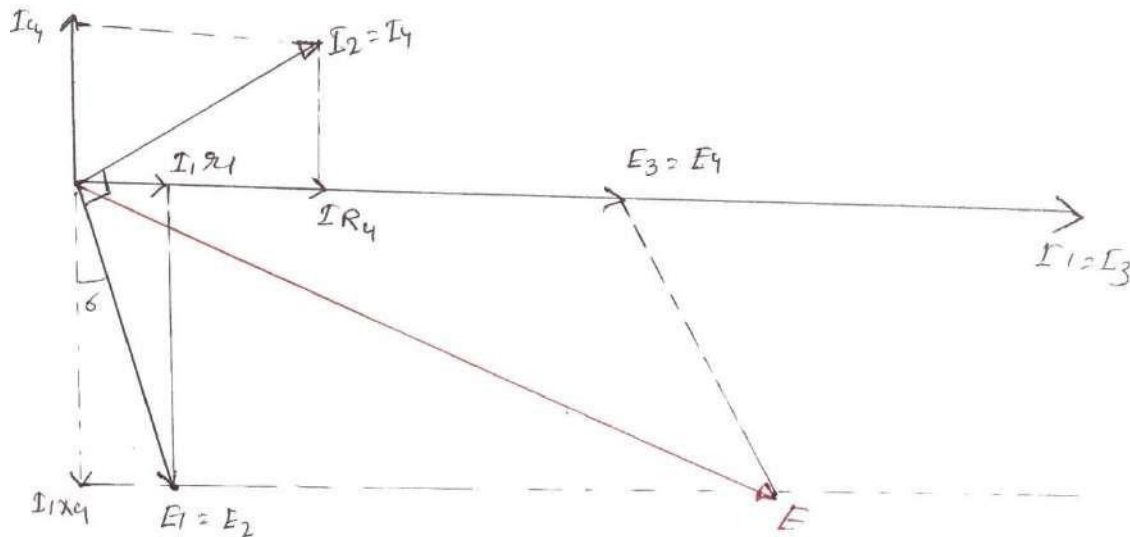

Fig 2.22 Phasor diagram of Schering bridge

At balance condition, $\dot{Z}_1 \dot{Z}_4 = \dot{Z}_2 \dot{Z}_3$

$$\frac{1 + j\omega C_1 r_1}{j\omega C_1} \times \frac{R_4}{1 + j\omega C_4 R_4} = \frac{R_3}{j\omega C_2}$$

$$(1 + j\omega C_1 r_1) R_4 C_2 = R_3 C_1 (1 + j\omega C_4 R_4)$$

$$R_2 C_2 + j\omega C_1 r_1 R_4 C_2 = R_3 C_1 + j\omega C_4 R_4 R_3 C_1$$

Comparing the real part,

$$\therefore C_1 = \frac{R_4 C_2}{R_3}$$

Comparing the imaginary part,

$$\omega C_1 r_1 R_4 C_2 = \omega C_4 R_3 R_4 C_1$$

$$r_1 = \frac{C_4 R_3}{C_2}$$

Dissipation factor of capacitor,

$$D = wC_1r_1 = w \times \frac{R_4C_2}{R_3} \times \frac{C_4R_3}{C_2}$$

$$\therefore D = wC_4R_4$$

Advantages

- ✓ In this type of bridge, the value of capacitance can be measured accurately.
- ✓ It can measure capacitance value over a wide range.
- ✓ It can measure dissipation factor accurately.

Disadvantages

- ✓ It requires two capacitors.
- ✓ Variable standard capacitor is costly.

Measurements of frequency

Wein's bridge

Wein's bridge is popularly used for measurements of frequency of frequency. In this bridge, the value of all parameters are known. The source whose frequency has to measure is connected as shown in the figure.

$$Z_1 = r_1 + \frac{1}{j\omega C_1} = \frac{j\omega C_1 r_1 + 1}{j\omega C_1}$$

$$Z_2 = \frac{R_2}{1 + j\omega C_2 R_2}$$

At balance condition, $\dot{Z}_1 \dot{Z}_4 = \dot{Z}_2 \dot{Z}_3$

$$\frac{j\omega C_1 r_1 + 1}{j\omega C_1} \times R_4 = \frac{R_2}{1 + j\omega C_2 R_2} \times R_3$$

$$(1 + j\omega C_1 r_1)(1 + j\omega C_2 R_2)R_4 = R_2 R_3 \times j\omega C_1$$

$$\left[1 + j\omega C_2 R_2 + j\omega C_1 r_1 - \omega^2 C_1 C_2 r_1 R_2 \right] = j\omega C_1 \frac{R_2 R_3}{R_4}$$

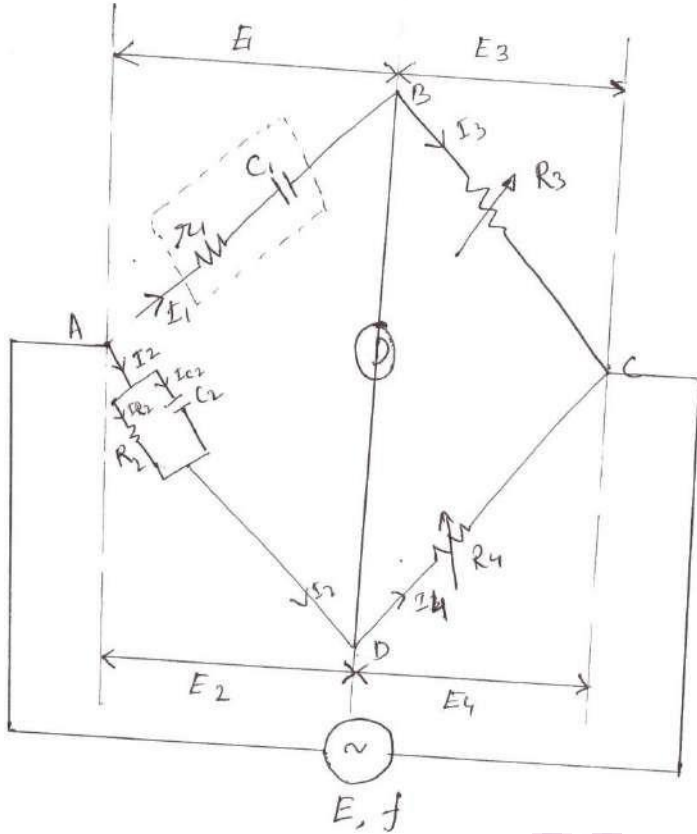

Fig 2.23 Wein's bridge

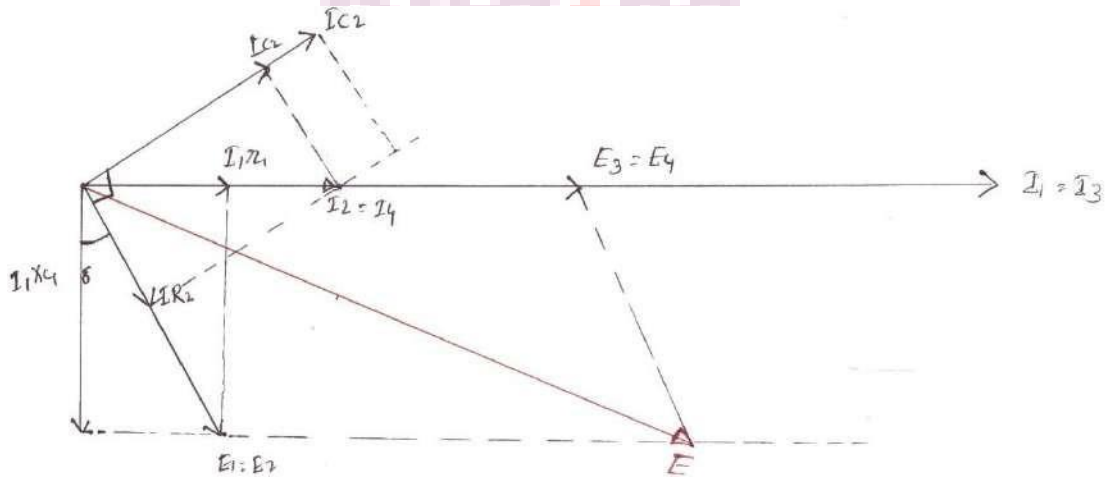

Fig 2.24 Phasor diagram of Wein's bridge

Comparing real
term,

$$1 - \omega^2 C_1 C_2 r_1 R_2$$

$$= 0$$

$$\omega^2 C_1 C_2 r_1 R_2 = 1$$

$$\omega^2 = \frac{1}{C_1 C_2 r_1 R_2}$$

$$\omega = \frac{1}{\sqrt{C_1 C_2 r_1 R_2}} \quad f = \frac{1}{2\pi \sqrt{C_1 C_2 r_1 R_2}}$$



Ballistic galvanometer

This is a sophisticated instrument. This works on the principle of PMMC meter. The only difference is the type of suspension is used for this meter. Lamp and glass scale method is used to obtain the deflection. A small mirror is attached to the moving system. Phosphorous bronze wire is used for suspension.

When the D.C. voltage is applied to the terminals of moving coil, current flows through it. When a current carrying coil kept in the magnetic field, produced by permanent magnet, it experiences a force. The coil deflects and mirror deflects. The light spot on the glass scale also move. This deflection is proportional to the current through the coil.

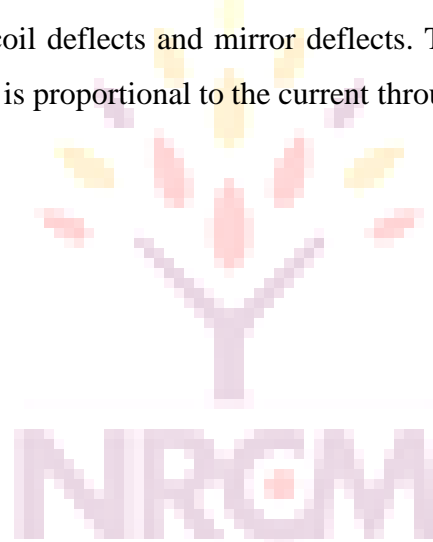

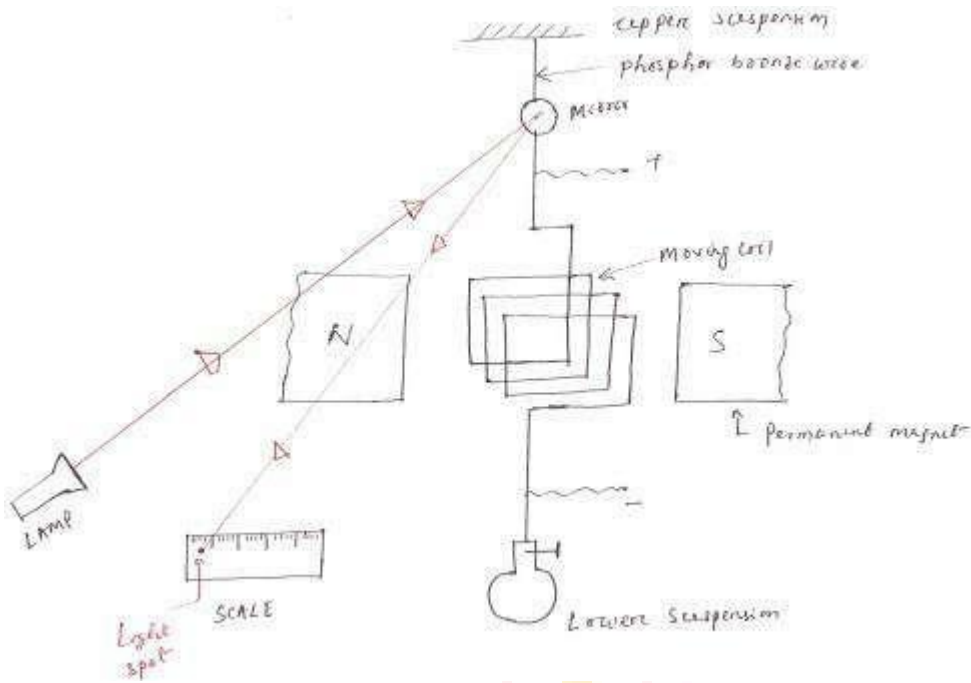

Fig 2.27 Ballistic galvanometer

Measurements of flux and flux density (Method of reversal)

D.C. voltage is applied to the electromagnet through a variable resistance R_1 and a reversing switch. The voltage applied to the toroid can be reversed by changing the switch from position 2 to position '1'. Let the switch be in position '2' initially. A constant current flows through the toroid and a constant flux is established in the core of the magnet.

A search coil of few turns is provided on the toroid. The B.G. is connected to the searchcoil through a current limiting resistance. When it is required to measure the flux, the switch is changed from position '2' to position '1'. Hence the flux reduced to zero and it starts increasing in the reverse direction. The flux goes from $+\phi$ to $-\phi$, in time 't' second. An emf is induced in the search coil, since the flux changes with time. This emf circulates a current through R_2 and B.G. The meter deflects. The switch is normally closed. It is opened when it is required to take the reading.

Plotting the BH curve

The curve drawn with the current on the X-axis and the flux on the Y-axis, is called magnetization characteristics. The shape of B-H curve is similar to shape of magnetization characteristics. The residual magnetism present in the specimen can be removed as follows.

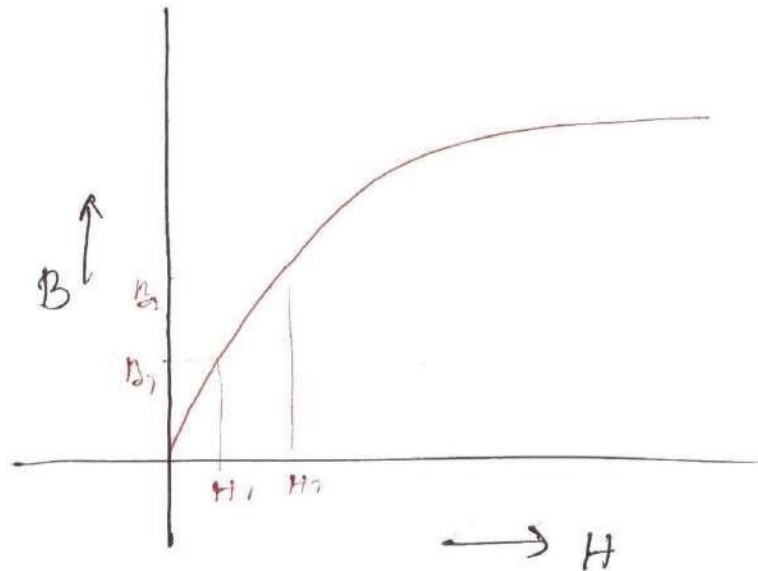

Fig 2.28 BH curve

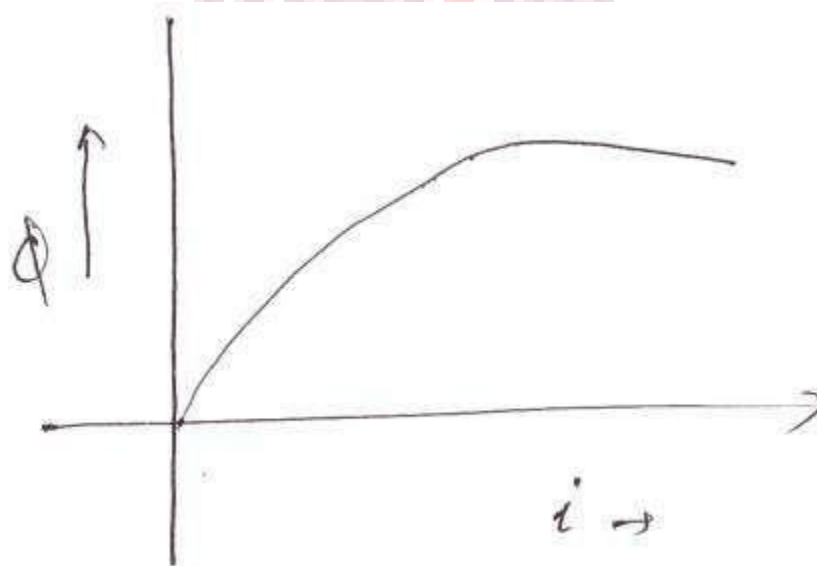

Fig 2.29 Magnetization characteristics

Close the switch 'S₂' to protect the galvanometer, from high current. Change the switch S₁ from position '1' to '2' and vice versa for several times.

To start with the resistance 'R₁' is kept at maximum resistance position. For a particular value of current, the deflection of B.G. is noted. This process is repeated for various value of current. For

each deflection flux can be calculated. ($\phi = \frac{B \times l}{\mu_0 \mu_r N^2 A}$)

Magnetic field intensity value for various current can be calculated. (H). The B-H curve can be plotted by using the value of 'B' and 'H'.



NATIONAL RESEARCH CENTRE FOR MICROELECTRONICS

UNIT – V TRANSDUCERS

Transducers

Definition of transducers – Classification of transducers – Advantages of Electrical transducers – Characteristics and choice of transducers – Principle operation of resistor, inductor, LVDT and capacitor transducers – LVDT Applications – Strain gauge and its principle of operation – Gauge factor – Thermistors – Thermocouples – Synchros – Piezo electric transducers – Photo diodes.

INTRODUCTION

A device which converts a physical quantity into the proportional electrical signal is called a transducer. The electrical signal produced may be a voltage, current or frequency. A transducer uses many effects to produce such conversion. The process of transforming signal from one form to other is called transduction. A transducer is also called pick up. The transduction element transforms the output of the sensor to an electrical output, as shown in the Fig.

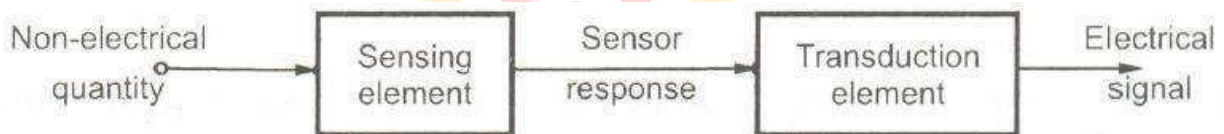

A transducer will have basically two main components. They are

1. Sensing Element

The physical quantity or its rate of change is sensed and responded to by this part of the transducer.

2. Transduction Element

The output of the sensing element is passed on to the transduction element. This element is responsible for converting the non-electrical signal into its proportional electrical signal.

There may be cases when the transduction element performs the action of both transduction and sensing. The best example of such a transducer is a thermocouple. A thermocouple is used to generate a voltage corresponding to the heat that is generated at the junction of two dissimilar metals.

Classification of Transducers

The Classification of Transducers is done in many ways. Some of the criteria for the classification are based on their area of application, Method of energy conversion, Nature of output signal, According to Electrical principles involved, Electrical parameter used, principle of operation, &

Typical applications.

The transducers can be classified broadly

- i. On the basis of transduction form used
- ii. As primary and secondary transducers
- iii. As active and passive transducers
- iv. As transducers and inverse transducers.

Broadly one such generalization is concerned with energy considerations wherein they are classified as active & Passive transducers. A component whose output energy is supplied entirely by its input signal (physical quantity under measurement) is commonly called a „passive transducer“. In other words the passive transducers derive the power required for transduction from an auxiliary source. Active transducers are those which do not require an auxiliary power source to produce their output. They are

also known as self generating type since they produce their own voltage or current output. Some of the passive transducers (electrical transducers), their electrical parameter (resistance, capacitance, etc), principle of operation and applications are listed below.

Resistive Transducers

1. Resistance Strain Gauge – The change in value of resistance of metal semi-conductor due to elongation or compression is known by the measurement of torque, displacement or force.
2. Resistance Thermometer – The change in resistance of metal wire due to the change in temperature known by the measurement of temperature.
3. Resistance Hygrometer – The change in the resistance of conductive strip due to the change of moisture content is known by the value of its corresponding humidity.
4. Hot Wire Meter – The change in resistance of a heating element due to convection cooling of a flow of gas is known by its corresponding gas flow or pressure.
5. Photoconductive Cell – The change in resistance of a cell due to a corresponding change in light flux is known by its corresponding light intensity.
6. Thermistor – The change in resistance of a semi-conductor that has a negative co-efficient of resistance is known by its corresponding measure of temperature.
7. Potentiometer Type – The change in resistance of a potentiometer reading due to the movement of the slider as a part of an external force applied is known by its corresponding pressure or displacement.

Capacitance Transducers

1. Variable capacitance pressure gage-

Principle of operation: Distance between two parallel plates is varied by an externally applied force
Applications: Measurement of Displacement, pressure

2. Capacitor microphone

Principle of operation: Sound pressure varies the capacitance between a fixed plate and a movable diaphragm. Applications: Speech, music, noise

3. Dielectric gauge

Principle of operation: Variation in capacitance by changes in the dielectric.

Applications: Liquid level, thickness

Inductance Transducers

Electrical Measurements & Instrumentation (EE3101PC)

1. Magnetic circuit transducer
Principle of operation: Self inductance or mutual inductance of ac-excited coil is varied by changes in the magnetic circuit. Applications: Pressure, displacement
2. Reluctance pickup
Principle of operation: Reluctance of the magnetic circuit is varied by changing the position of the iron core of a coil. Applications: Pressure, displacement, vibration, position
3. Differential transformer
Principle of operation: The differential voltage of two secondary windings of a transformer is varied by positioning the magnetic core through an externally applied force. Applications: Pressure, force, displacement, position
4. Eddy current gauge
Principle of operation: Inductance of a coil is varied by the proximity of an eddy current plate. Applications: Displacement, thickness
5. Magnetostriction gauge
Principle of operation: Magnetic properties are varied by pressure and stress. Applications: Force, pressure, sound

Voltage and current Transducers

1. Hall effect pickup
Principle of operation: A potential difference is generated across a semiconductor plate (germanium) when magnetic flux interacts with an applied current. Applications: Magnetic flux, current
2. Ionization chamber
Principle of operation: Electron flow induced by ionization of gas due to radioactive radiation. Applications: Particle counting, radiation
3. Photoemissive cell
Principle of operation: Electron emission due to incident radiation on photoemissive surface. Applications: Light and radiation
4. Photo multiplier tube
Principle of operation: Secondary electron emission due to incident radiation on photosensitive cathode. Applications: Light and radiation, photo-sensitive relays

Self-Generating Transducers (No External Power) – Active Transducers

They do not require an external power, and produce an analog voltage or current when stimulated by some physical form of energy.

1. Thermocouple and thermopile
Principle of operation: An emf is generated across the junction of two dissimilar metals or semiconductors when that junction is heated. Applications: Temperature, heat flow, radiation.
2. Moving-coil generator
Principle of operation: Motion of a coil in a magnetic field generates a voltage. Applications: Velocity. Vibration

3. Piezoelectric pickup

An emf is generated when an external force is applied to certain crystalline materials, such as quartz. Sound, vibration, acceleration, pressure changes

4. Photovoltaic cell

Principle of operation: A voltage is generated in a semi-conductor junction device when radiant energy stimulates the cell. Applications: Light meter, solar cell

Primary Transducers and Secondary Transducers- Bourden tube acting as a primary detector senses the pressure and converts the pressure into a displacement of its free end. The displacement of the free end moves the core of a linear variable differential transformer (LVDT) which produces an output voltage.

Analog Transducers- These transducers convert the input quantity into an analog output which is a continuous function of time. ◦ Strain Gauge ◦ LVDT ◦ Thermocouple ◦ Thermistor

Digital Transducers- These transducers convert the input quantity into an electrical output which is in the form of pulses. ◦ Glass Scale can be read optically by means of a light source, an optical system and photocells

Transducers and Inverse Transducers- -A Transducer can be broadly defined as a device which converts a non-electrical quantity into an electrical quantity. Ex:-Resistive, inductive and capacitive transducers -An inverse transducer is defined as a device which converts an electrical quantity into a non-electrical quantity. Ex:-Piezoelectric crystals

Advantages of Electrical transducers

Mostly quantities to be measured are non-electrical such as temperature, pressure, displacement, humidity, fluid flow, speed etc., but these quantities cannot be measured directly. Hence such quantities are required to be sensed and changed into some other form for easy measurement. Electrical quantities such as current, voltage, resistance, inductance and capacitance etc. can be conveniently measured, transferred and stored, and, therefore, for measurement of the non-electrical quantities these are to be converted into electrical quantities first and then measured. The function of converting non-electrical quantity into electrical one is accomplished by a device called the electrical transducer.

Basically an electrical transducer is a sensing device by which a physical, mechanical or optical quantity to be measured is transformed directly, with a suitable mechanism, into an electrical signal (current, voltage and frequency). The production of these signals is based upon electrical effects which may be resistive, inductive, capacitive etc. in nature. The input versus output energy relationship takes a definite reproducible function. The output to input and the output to time behavior is predictable to a known degree of accuracy, sensitivity and response, within the specified environmental conditions. Electrical transducers have numerous advantages. Modern digital computers have made use of electrical transducers absolutely essential.

Electrical transducers suffer due to some draw-backs too, such as low reliability in comparison to that of mechanical transducers due to the ageing and drift of the active components and comparative high cost of electrical transducers and associated signal conditioners. In some cases the accuracy and resolution attainable are not as high as in mechanical transducers.

Some of the advantages are:

1. Electrical amplification and attenuation can be done easily and that too with a static device.
2. The effect of friction is minimized.
3. The electric or electronic system can be controlled with a very small electric power.
4. The electric power can be easily used, transmitted and processed for the purpose of measurement.

Factor to be considered while selecting transducer:

It should have high input impedance and low output impedance, to avoid loading effect. It should have good resolution over its entire selected range.

It must be highly sensitive to desired signal and insensitive to unwanted signal. Preferably small in size.

It should be able to work in a corrosive environment.

It should be able to withstand pressure, shocks, vibrations etc.. It must have a high degree of accuracy and repeatability. Selected transducer must be free from errors.

The transducer circuit should have overload protection so that it will withstand overloads.

Requirements of a good transducers

- Smaller in size and weight.
- High sensitivity.
- Ability to withstand environmental conditions.
- Low cost.

RESISTIVE TRANSDUCERS

Resistance of an electrical conductor is given by,

$$R = \rho l / A$$

Where ,

R = Resistance in „Ω“

P = Resistivity of the conductor (Ω

- cm)
l = Length of the conductor

in cm.

A = Cross-sectional area of the metal conductor in cm²

It is clear from the equation that, the electrical resistance can be varied by varying,

- (i) Length
- (ii) Cross-sectional area and
- (iii) Resistivity or combination of these.

Principle:-

A change in resistance of a circuit due to the displacement of an object is the measure of displacement of that object, method of changing the resistance and the resulting devices are summarized in the following

Method of changing resistance-

Length - Resistance can be changed varying the length of the conductor, (linear and rotary).

Dimensions - When a metal conductor is subjected to mechanical strain, change in dimensions of the conductor occurs, that changes the resistance of the conductor.

Resistivity -

When a metal conductor is subjected to a change in temperature and change in resistivity occurs which changes resistance of the conductor.

Resulting device:-

Resistance potentiometers or sliding contact devices displacements, Electrical resistance strain gauges. Thermistor and RTD

Use:-

the resistive transducer used for the measurement of linear and angular, and used for the temperature mechanical strain measurement.

How Potentiometer works

A potentiometer is a resistive sensor used to measure linear displacements as well as rotary motion. In a potentiometer an electrically conductive wiper slides across a fixed resistive element. A voltage is applied across the resistive element. Thus a voltage divider circuit is formed. The output voltage (V_{out}) is measured as shown in the figure below. The output voltage is proportional to the distance travelled.

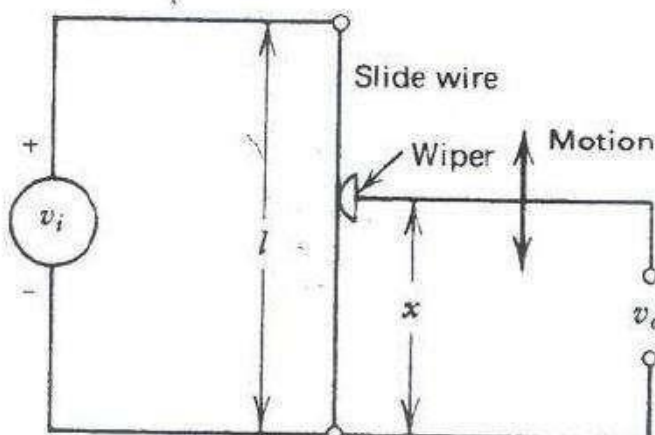

There are two types of potentiometer, linear and rotary potentiometer. The linear potentiometer

has a slide or wiper. The rotary potentiometer can be a single turn or multi turn.



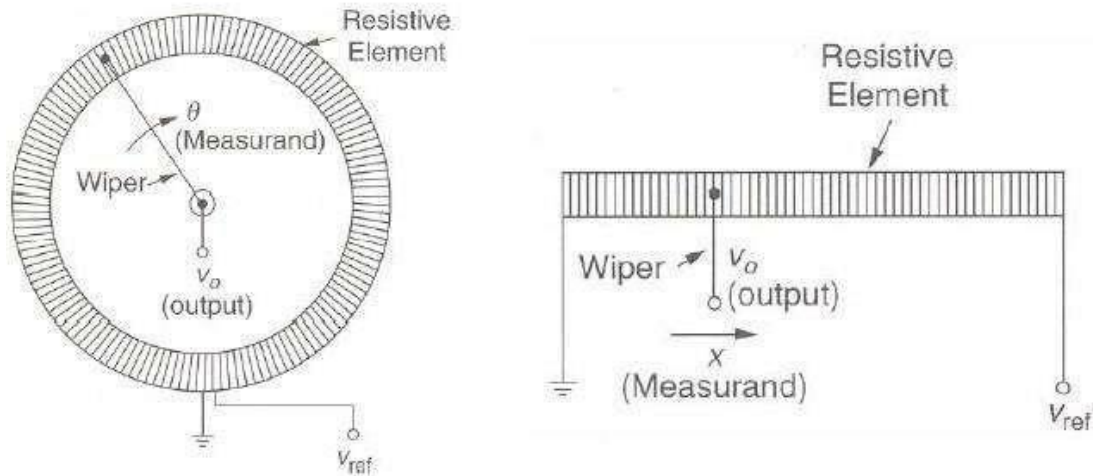

The important parameters while selecting a potentiometer are

- Operating temperature
- Shock and vibration
- Humidity
- Contamination and seals
- life cycle
- dither

Types of Potentiometer:

Wire-Wound type potentiometer

- The resistance range between 10Ω and $10M\Omega$
- The resistance increase in a step wise manner.
 - It is possible to construct potentiometers with 100 –200 turns per cm length (The resolution range between 0.1 to 0.05mm).
- Linear potentiometers are available in many lengths up to 1m.
 - Helical potentiometers are commercially available with 50 to 60 turns (The angular displacement is between 18000 – 21600 degree)
- Potentiometer life exceed 1 million cycles.

Thin film type potentiometer

- Higher resolution.
- Lower noise.
- Longer life (exceed 10 million cycles)
- Resistance of 50 to 100 Ω /mm can be obtained with conductive plastic film.
- Commercially available resolution is 0.001mm.

- Power rating
$$P = \frac{V_{in}^2}{R_p}$$
$$V_{in(max)} = \sqrt{PR_p}$$
- Sensitivity
$$V_o = \frac{V_{in}}{L} x$$
$$Sensitivity = \frac{V_{in}}{L}$$
- Linearity
$$V_o = V_{in} \left(\frac{R}{R_p} \right) \left[\frac{R_M/R_p}{(R_M/R_p) + (R/R_p) - (R/R_p)^2} \right]$$
- Optimum sensitivity (0.2 V/degree and 2 V/cm)

Some of the advantages of the potentiometer are

- Easy to use
- low cost
- High amplitude output
- Proven technology
- Easily available

Some of the disadvantages of the potentiometer are

- Since the wiper is sliding across the resistive element there is a possibility of friction and wear. Hence the number of operating cycles are limited.
- Limited bandwidth
- Inertial loading

Some of the applications of the potentiometer are

- Linear displacement measurement
- Rotary displacement measurement
- Volume control
- Brightness control
- Liquid level measurements using float

Strain Gauge

Strain gage is one of the most popular types of transducer. It has got a wide range of applications. It can be used for measurement of force, torque, pressure, acceleration and many other parameters.

The basic principle of operation of a strain gage is simple: when strain is applied to a thin metallic wire, its dimension changes, thus changing the resistance of the wire. Let us first

investigate what are the factors, responsible for the change in resistance.



Gage Factor

Let us consider a long straight metallic wire of length l circular cross section with diameter d (fig). When this wire is subjected to a force applied at the two ends, a strain will be generated and as a result, the

dimension will change (l changing to $l + \Delta l$, d changing to $d + \Delta d$ and A changing to $A + \Delta A$). For the time being, we are considering that all the changes are in positive direction. Now the resistance of the wire:

Let us consider a long straight metallic wire of length l circular cross section with diameter d (fig. 5). When this wire is subjected to a force applied at the two ends, a strain will be generated and as a result, the dimension will change (l changing to $l + \Delta l$, d changing to $d + \Delta d$ and A changing to $A + \Delta A$). For the time being, we are considering that all the changes are in positive direction. Now the resistance of the wire:

$$R = \frac{\rho l}{A}, \text{ where } \rho \text{ is the resistivity.}$$

From the above expression, the change in resistance due to strain:

$$\begin{aligned} \Delta R &= \left(\frac{\partial R}{\partial l} \right) \Delta l + \left(\frac{\partial R}{\partial A} \right) \Delta A + \left(\frac{\partial R}{\partial \rho} \right) \Delta \rho \\ &= \frac{\rho}{A} \Delta l - \frac{\rho}{A^2} \Delta A + \frac{l}{A} \Delta \rho \\ &= R \frac{\Delta l}{l} - R \frac{\Delta A}{A} + R \frac{\Delta \rho}{\rho} \end{aligned}$$

or,

$$\frac{\Delta R}{R} = \frac{\Delta l}{l} - \frac{\Delta A}{A} + \frac{\Delta \rho}{\rho} \quad (6)$$

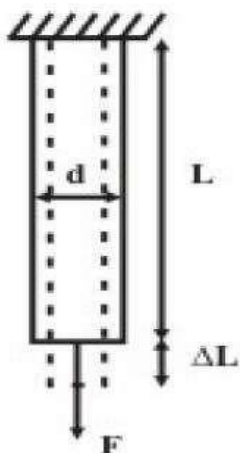

Fig: Change of Resistance with strain

Electrical Measurements & Instrumentation (EE3101PC)

Now, for a circular cross section, $A = \frac{\pi d^2}{4}$; from which, $\Delta A = \frac{\pi d}{2} \Delta d$. Alternatively,

$$\frac{\Delta A}{A} = 2 \frac{\Delta d}{d}$$

Hence,

$$\frac{\Delta R}{R} = \frac{\Delta l}{l} - 2 \frac{\Delta d}{d} + \frac{\Delta \rho}{\rho} \quad (7)$$

Now, the *Poisson's Ratio* is defined as:

$$\nu = -\frac{\text{lateral strain}}{\text{longitudinal strain}} = -\frac{\Delta d/d}{\Delta l/l}$$

The Poisson's Ratio is the property of the material, and does not depend on the dimension. So, (6) can be rewritten as:

$$\frac{\Delta R}{R} = (1 + 2\nu) \frac{\Delta l}{l} + \frac{\Delta \rho}{\rho}$$

Hence,

$$\frac{\Delta R/R}{\Delta l/l} = 1 + 2\nu + \frac{\Delta \rho/\rho}{\Delta l/l}$$

The last term in the right hand side of the above expression, represents the change in resistivity of the material due to applied strain that occurs due to the *piezo-resistance property* of the material. In fact, all the elements in the right hand side of the above equation are independent of the geometry of the wire, subjected to strain, but rather depend on the material property of the wire. Due to this reason, a term *Gage Factor* is used to characterize the performance of a strain gage. The Gage Factor is defined as:

$$G := \frac{\Delta R/R}{\Delta l/l} = 1 + 2\nu + \frac{\Delta \rho/\rho}{\Delta l/l} \quad (8)$$

For normal metals the Poisson's ratio ν varies in the range:

$$0.3 \leq \nu \leq 0.6,$$

while the piezo-resistance coefficient varies in the range:

$$0.2 \leq \frac{\Delta \rho/\rho}{\Delta l/l} \leq 0.6.$$

Thus, the Gage Factor of metallic strain gages varies in the range 1.8 to 2.6. However, the semiconductortype strain gages have a very large Gage Factor, in the range of 100-150. This is attained due to dominant piezo-resistance property of semiconductors. The commercially available strain gages have certain fixed resistance values, such as, 120 Ω , 350 Ω , 1000 Ω , etc. The manufacturer also specifies the Gage Factor and the maximum gage current to avoid self-heating (normally in the range 15 mA to 100 mA).

The choice of material for a metallic strain gage should depend on several factors. The material should have low temperature coefficient of resistance. It should also have low coefficient for thermal expansion. Judging from all these factors, only few alloys qualify for a commercial metallic strain gage. They are: *Advance* (55% Cu, 45% Ni): Gage Factor between 2.0 to 2.2

Nichrome (80% Ni, 20% Co): Gage Factor between 2.2 to 2.5

Apart from these two, *Isoelastic* -another trademarked alloy with Gage Factor around 3.5 is also in use. Semiconductor type strain gages, though having large Gage Factor, find limited use, because of their high sensitivity and nonlinear characteristics.

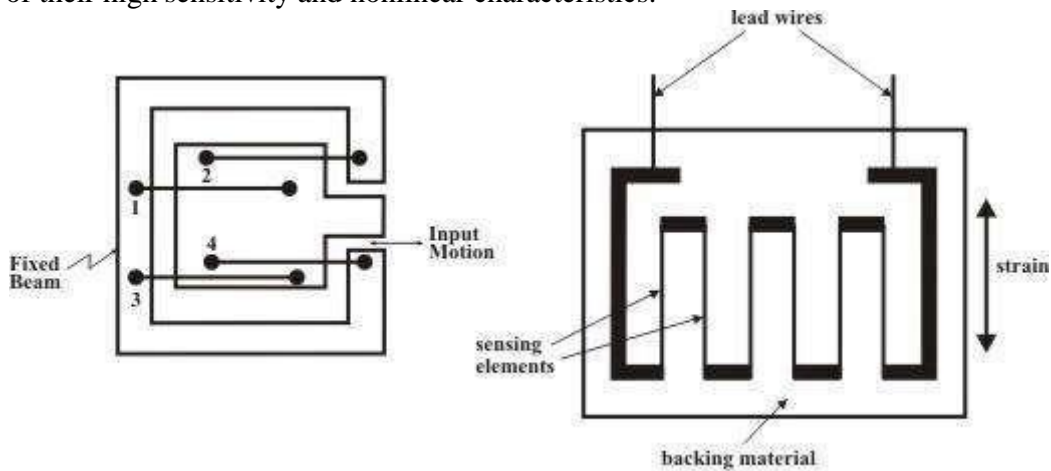

Fig. 6 (a) Unbonded metallic strain gage, (b) bonded metal foil type strain gage

Metallic Strain Gage

Most of the strain gages are metallic type. They can be of two types: *unbonded* and *bonded*. The unbonded strain gage is normally used for measuring strain (or displacement) between a fixed and a moving structure by fixing four metallic wires in such a way, so that two are in compression and two are in tension, as shown in fig. 6 (a). On the other hand, in the bonded strain gage, the element is fixed on a backing material, which is permanently fixed over a structure, whose strain has to be measured, with adhesive. Most commonly used bonded strain gages are *metal foil type*. The construction of such a strain gage is shown in fig. 6(b). The metal foil type strain gage is manufactured by photo-etching technique. Here the thin strips of the foil are the active elements of the strain gage, while the thick ones are for providing electrical connections. Because of large area of the thick portion, their resistance is small and they do not contribute to any change in resistance due to strain, but increase the heat dissipation area. Also it is easier to connect the lead wires with the strain gage. The strain gage in fig. 6(b) can measure strain in one direction only. But if we want to measure the strain in two or more directions at the same point,

element strain gage rosette stacked at 45° .

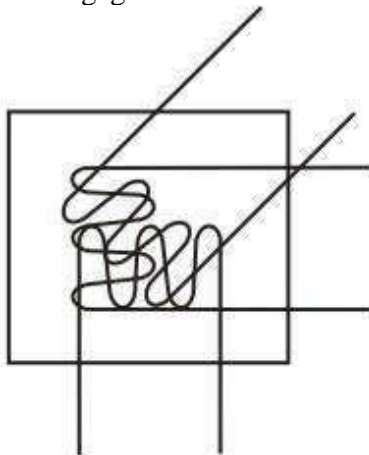

Fig. 7 Three-element strain gage rosette- 45° stacked.

The *backing material*, over which the strain gage is fabricated and which is fixed with the strain measuring structure has to satisfy several important properties. Firstly, it should have high mechanical strength; it should also have high dielectric strength. But the most important it should have is that it should be non-hygroscopic, otherwise, absorption of moisture will cause bulging and generate local strain. The backing materials normally used are impregnated paper, fibre glass, etc. The *bonding material* used for fixing the strain gage permanently to the structure should also be non-hygroscopic. Epoxy and Cellulose are the bonding materials normally used.

Semiconductor type Strain Gage

Semiconductor type strain gage is made of a thin wire of silicon, typically 0.005 inch to 0.0005 inch, and length 0.05 inch to 0.5 inch. They can be of two types: *p*-type and *n*-type. In the former the resistance increases with positive strain, while, in the later the resistance decreases with temperature. The construction and the typical characteristics of a semiconductor strain gage are shown in fig.8.

MEMS pressure sensors is now a days becoming increasingly popular for measurement of pressure. It is made of a small silicon diagram with four piezo-resistive strain gages mounted on it. It has an in-built signal conditioning circuits and delivers measurable output voltage corresponding to the pressure applied. Low weight and small size of the sensor make it suitable for measurement of pressure in specific applications.

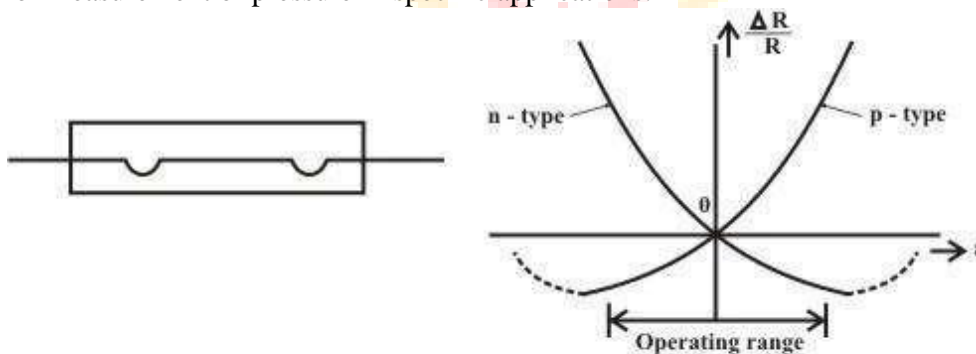

Fig. 8 (a) construction and (b) characteristics of a semiconductor strain gage

Thermistors:

Basically thermistor is a contraction of a word 'thermal resistors', The resistors depending on temperature are thermal resistors. Thus resistance thermometers are also thermistors having positive

-temperature coefficients. But generally the resistors having negative temperature coefficients (NTC) are called thermistors. The resistance of a thermistor decreases as temperature increases. The NTC of thermistors can be as large as few percent per degree celcius change in temperature. Thus the thermistors are very sensitive and can detect very small changes in temperature too.

Construction of thermistor:

Thermistors are composed of a sintered mixture of metallic oxides, such as manganese, nickel, cobalt, copper, iron, and uranium. Their resistances at ambient temperature may range from 100 nto 100 ill. Thermistors are available in a wide variety of shapes and sizes as shown in the Fig.

Electrical Measurements & Instrumentation (EE3101PC)

Smallest in size are the beads with a diameter of 0.15 mm to 1.25 mm. Beads may be sealed in the tips of solid glass rods to form probes. Disks and washers are made by pressing thermistor

material under high pressure into flat cylindrical shapes. Washers can be placed in series or in parallel to increase power dissipation rating.

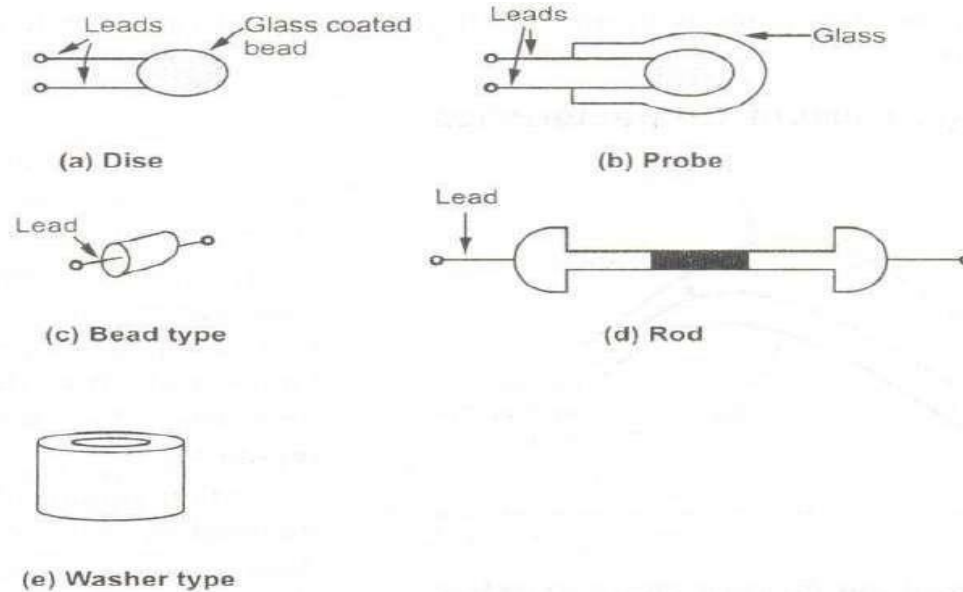

Thermistors are well suited for precision temperature measurement, temperature control, and temperature compensation, because of their very large change in resistance with temperature. They are widely used for measurements in the temperature range $-1000\text{ }^{\circ}\text{C}$ to $+2000\text{ }^{\circ}\text{C}$. The measurement of the change in resistance with temperature is carried out with a Wheatstone bridge.

Inductive Transducer

Inductive transducers work on the principle of inductance change due to any appreciable change in the quantity to be measured i.e. measured. For example, LVDT, a kind of **inductive transducers**, measures displacement in terms of voltage difference between its two secondary voltages.

Secondary voltages are nothing but the result of induction due to the flux change in the secondary coil with the displacement of the iron bar. Anyway LVDT is discussed here briefly to explain the principle of **inductive transducer**. LVDT will be explained in other article in more detail. For the time being let's focus on basic introduction of **inductive transducers**. Now first our motive is to find how the **inductive transducers** can be made to work. This can be done by changing the flux with the help of measured and this changing flux obviously changes the inductance and this inductance change can be calibrated in terms of measured. Hence **inductive transducers** use one of the following principles for its working.

1. Change of self inductance
2. Change of mutual inductance
3. Production of eddy current

Change of Self Inductance of Inductive Transducer

We know very well that self inductance of a coil is given by

Where, N = number of turns.

$$R = \frac{l}{\mu A} \qquad L = \frac{N^2}{R}$$

R = reluctance of the magnetic circuit. Also we know that reluctance R is given by

$$L = \frac{N^2 \mu A}{l}$$

where μ = effective permeability of the medium in and around the coil.

$$L = N^2 \mu G$$

Where, $G = A/l$ and called geometric form factor. A = area of cross-section of coil. l = length of the coil. So, we can vary self inductance by

- Change in number of turns, N ,
- Changing geometric configuration, G ,
- Changing permeability

For the sake of understanding we can say that if the displacement is to be measured by the **inductive transducers**, it should change any of the above parameter for causing in the change in self inductance.

Change of Mutual Inductance of Inductive Transducer

Here transducers, which work on change of mutual inductance principle, use multiple coils. We use here two coils for the sake of understanding. Both coils have their self inductance as well. So let's denote their self inductance by L_1 and L_2 . Mutual inductance between these two coils is given by

$$M = K \sqrt{L_1 L_2}$$

Thus mutual inductance can be changed by varying self inductance or by varying coefficient of coupling, K . The methods of changing self inductance we already discussed. Now coefficient of coupling depends on the distance and orientation between two coils. Thus for the measurement of displacement we can fix one coil and make other movable which moves with the source whose displacement is to be measured. With the change in distance in displacement coefficient of coupling changes and it causes the change in mutual inductance. This change in mutual inductance can be calibrated with the displacement and measurement can be done.

Production of Eddy Current of Inductive Transducer

We know that when a conducting plate is placed near a coil carrying alternating current, a circulating current is induced in the plate called "EDDY CURRENT". This principle is used in such type of **inductive transducers**. Actually what happens? When a coil is placed near to coil carrying alternating current, a circulating current is induced in it which in turn produces its own flux which try to reduce the flux of the coil carrying the current and hence inductance of the coil changes.

Electrical Measurements & Instrumentation (EE3101PC)

Nearer the plate is to the coil, higher will be eddy current and higher is the reduction in inductance and vice versa. Thus inductance of coil varied with the variation of distance between coil and plate. Thus the movement of the plate can be calibrated in terms of inductance change to measure the quantity like displacement.

Real Life Application of Inductive Transducer

Inductive transducers find application in proximity sensors which are used for position measurement, dynamic motion measurement, touch pads etc. Particularly **inductive transducer** is used for the detection of type of metal, finding missing parts or counting the number of objects.

Linear Variable differential transformer (LVDT)

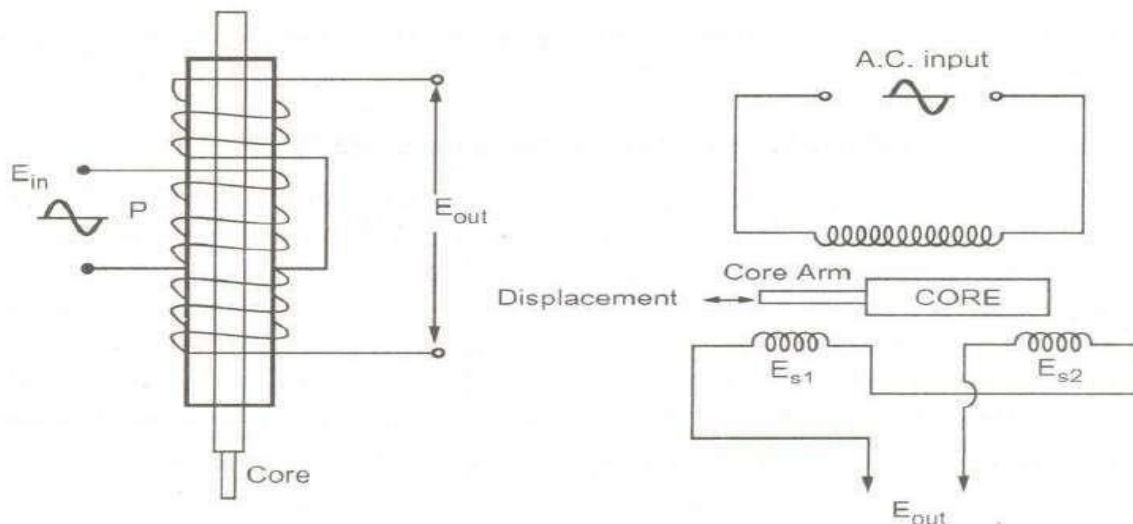

When an externally applied force moves the core to the left-hand position, more magnetic flux links the left-hand coil than the right-hand coil. The emf induced in the left-hand coil, E_{s1} , is therefore larger than the induced emf of the right-hand coil, E_{s2} . The magnitude of the output voltage is then equal to the difference between the two secondary voltages and it is in phase with the voltage of the left-hand coil.

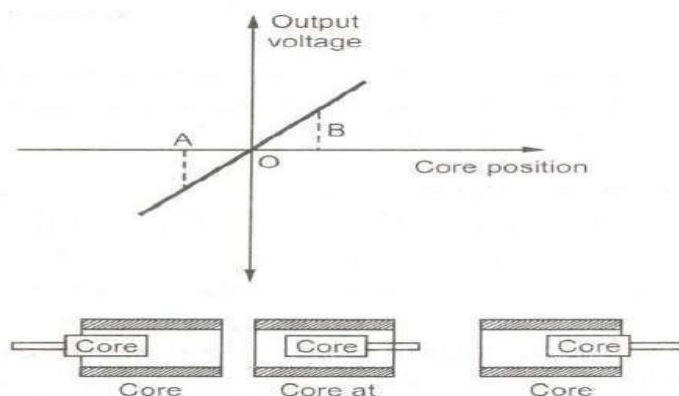

Output voltage of LVDT at different core positions

Construction of LVDT

Main Features of Construction are as,

- The transformer consists of a primary winding P and two secondary winding S1 and S2 wound on acylindrical former(which is hollow in nature and will contain core).
- Both the secondary windings have equal number of turns and are identically placed on the either side of primary winding
- The primary winding is connected to an AC source which produces a flux in the air gap and voltages are induced in secondary windings.
- A movable soft iron core is placed inside the former and displacement to be measured is connected to the iron core.
- The iron core is generally of high permeability which helps in reducing harmonics and high sensitivity of LVDT.
- The LVDT is placed inside a stainless steel housing because it will provide electrostatic and electromagnetic shielding.
- The both the secondary windings are connected in such a way that resulted output is the difference of the voltages of two windings.

Principle of Operation and Working

As the primary is connected to an AC source so alternating current and voltages are produced in the secondary of the LVDT. The output in secondary S₁ is e₁ and in the secondary S₂ is e₂. So the differential output is, $e_{out} = e_1 - e_2$ This equation explains the **principle of Operation of LVDT**.

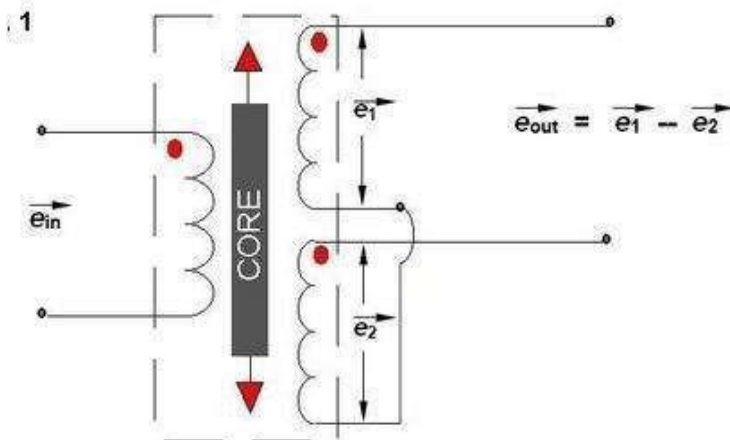

Now three cases arise according to the locations of core which explains the working of LVDT are discussed below as,

- **CASE I** When the core is at null position (for no displacement) When the core is at null position then the flux linking with both the secondary windings is equal so the induced emf is equal in both the windings. So for no displacement the value of output e_{out} is zero as e_1 and e_2 both are equal. So it shows that no displacement took place.

Electrical Measurements & Instrumentation (EE3101PC)

- **CASE II** When the core is moved to upward of null position (For displacement to the upward of reference point) In this case the flux linking with secondary winding S_1 is more as compared to flux linking with S_2 . Due to this e_1 will be more as that of e_2 . Due to this output voltage e_{out} is positive.
- **CASE III** When the core is moved to downward of Null position (for displacement to the downward of reference point) In this case magnitude of e_2 will be more as that of e_1 . Due to this output e_{out} will be negative and shows the output to downward of reference point.

Output V_s Core Displacement A linear curve shows that output voltage varies linearly with displacement of core.

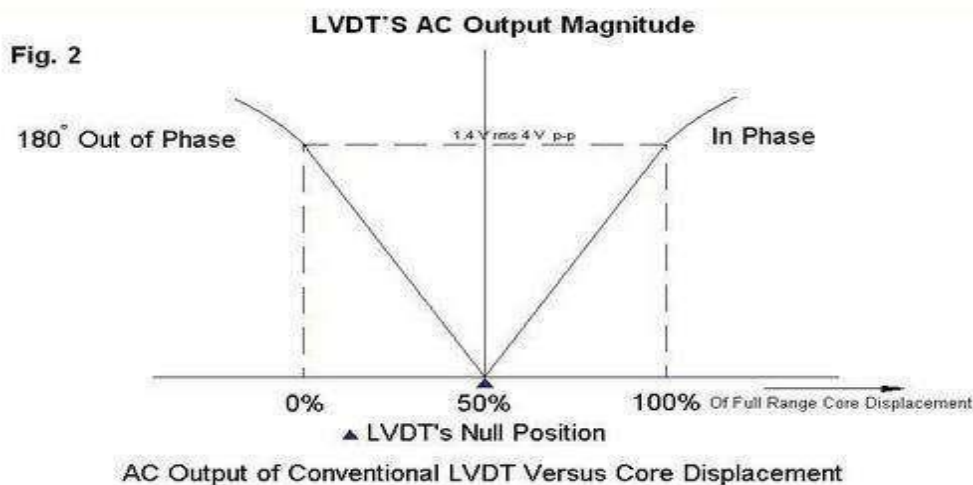

Some important points about magnitude and sign of voltage induced in LVDT

- The amount of change in voltage either negative or positive is proportional to the amount of movement of core and indicates amount of linear motion.
- By noting the output voltage increasing or decreasing the direction of motion can be determined
- The output voltage of an LVDT is linear function of core displacement.

Advantages of LVDT

- **High Range** - The LVDTs have a very high range for measurement of displacement. they can used for measurement of displacements ranging from 1.25mm to 250mm
- **No Frictional Losses** - As the core moves inside a hollow former so there is no loss of displacement input as frictional loss so it makes LVDT as very accurate device.
- **High Input and High Sensitivity** - The output of LVDT is so high that it doesn't need any Amplification .the transducer possesses a high sensitivity which is typically about 40V/mm.
- **Low Hysteresis** - LVDTs show a low hysteresis and hence repeatability is excellent under all conditions
- **Low Power Consumption** - The power is about 1W which is very as compared to other transducers.

- **Direct Conversion to Electrical Signals** - They convert the linear displacement to electrical voltage which are easy to process

Disadvantages of LVDT

- LVDT is sensitive to stray magnetic fields so they always require a setup to protect them from stray magnetic fields.
- They are affected by vibrations and temperature.

It is concluded that they are advantageous as compared than any other inductive transducers.

Applications of LVDT

1. They are used in applications where displacements ranging from fraction of mm to few cm are to be measured. The LVDT acting as a primary Transducer converts the displacement to electrical signal directly.
2. They can also act as the secondary transducers. E.g. the Bourbon tube which acts as a primary transducer and convert pressure into linear displacement. then LVDT converts this displacement into electrical signal which after calibration gives the ideas of the pressure of fluid.

Capacitive Transducers

A capacitor consists of two conductors (plates) that are electrically isolated from one another by a nonconductor (dielectric). When the two conductors are at different potentials (voltages), the system is capable of storing an electric charge. The storage capability of a capacitor is measured in farads. The principle of operation of capacitive transducers is based upon the equation for capacitance of a parallel plate capacitor as shown in Fig.

Capacitance

$$C = \frac{\epsilon A}{D}$$

Where,

A = Overlapping area of plates; m²,

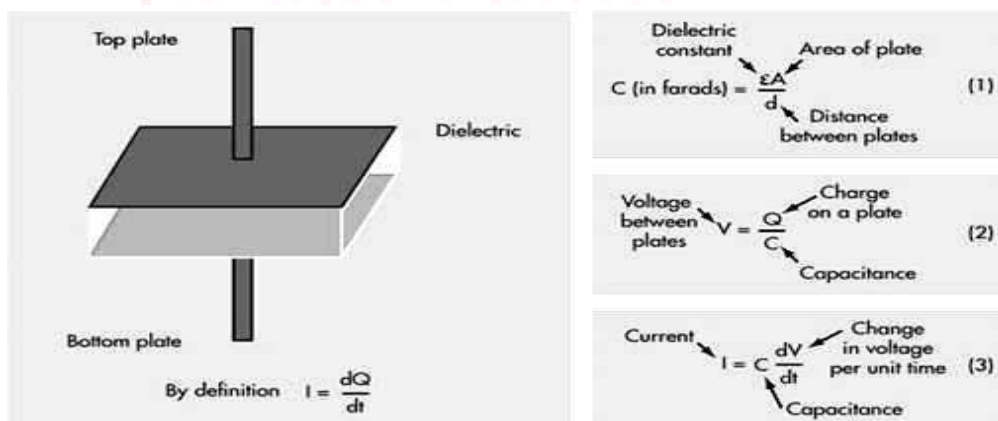

Fig. Parallel plate capacitor

d = Distance between two plates; m,

ε = Permittivity (dielectric constant); F/m.

The capacitance is measured with a bridge circuits. The output impedance Z of a capacitive transducer is:

$$Z = 1/2\pi fC$$

Where:
 Z = Impedance
 f = frequency, 50 Hz. C
= capacitance

In general, the output impedance of a capacitive transducer is high. This fact calls for a careful design of the output circuitry. The capacitive transducers work on the principle of change in capacitance of the capacitor. This change in capacitance could be caused by change in overlapping area A of the plates, change in the distance d between the plates and change in dielectric constant ϵ

In most of the cases the above changes are caused by the physical variables, such as, displacement, force or pressure. Variation in capacitance is also there when the dielectric medium between the plates changes, as in the case of measurement of liquid or gas levels. Therefore, the capacitive transducers are commonly used for measurement of linear displacement, by employing the following effects as shown in Fig a and figb.

- i) Change in capacitance due to change in overlapping area of plates.
- ii) Change in capacitance due to change in distance between the two plates.
- iii) Change in capacitance due to change in dielectric between the two plates

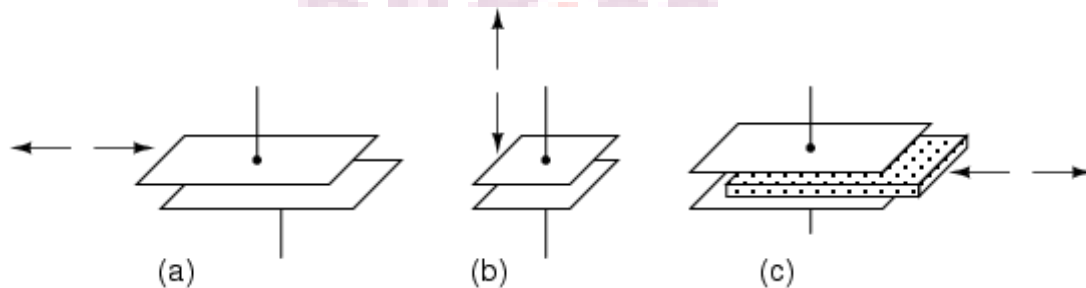

Fig.a Variable capacitive transducer varies; (a) area of overlap, (b) distance between plates, (c) amount of dielectric between plates

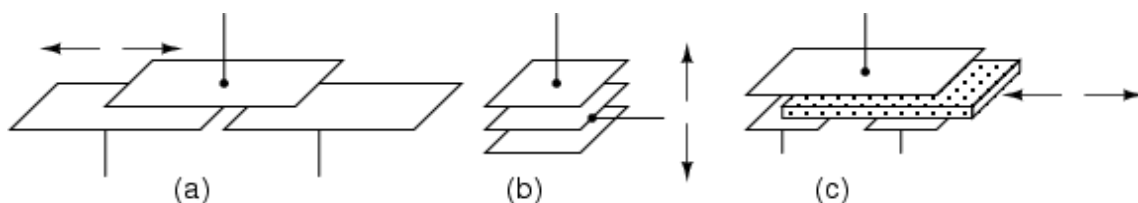

Fig.b Differential capacitive transducer varies capacitance ratio by changing: (a) area of overlap, (b) distance between plates, (c) dielectric between plates

As may be seen in Fig b, all of the differential devices have three wire connections rather than two: one wire for each of the end plates and one for the common plate. As the capacitance between one of the end plates and the common plate changes, the capacitance between the other end plate and the common plate also changes in the opposite direction.

a) Transducers Using Change in Area of Plates

Examining the equation for capacitance, it is found that the capacitance is directly proportional to the area, A of the plates. Thus, the capacitance changes linearly with change in area of plates. Hence this type of capacitive transducer is useful for measurement of moderate to large displacements say from 1 mm to several cm. The area changes linearly with displacement and also the capacitance.

For a parallel plate capacitor, the capacitance is:

$$C = \frac{\epsilon A}{d} = \frac{\epsilon l w}{d} F$$

Where, l = length of overlapping part of plates; m , and w
 w = width of overlapping part of plates; m .

$$\text{Sensitivity} \quad S = \frac{\partial C}{\partial l} = \epsilon \frac{w}{d} F/m$$

The sensitivity is constant and therefore there is linear relationship between capacitance and displacement.

This type of a capacitive transducer is suitable for measurement of linear displacement ranging from 1 to 10 cm. The accuracy is as high as 0.005%.

b) Transducers Using Change in Distance between Plates

Fig. 17.2(b) shows the basic form of a capacitive transducer employing change in distance between the two plates to cause the change in capacitance. One plate is fixed and the displacement to be measured is applied to the other plate which is movable. Since, the capacitance, C , varies inversely as the distance d , between the plates the response of this transducer is not linear. Thus this transducer is useful only for measurement of extremely small displacements.

$$\text{Sensitivity} \quad S = \frac{\partial C}{\partial l} = -\frac{\epsilon A}{d^2}$$

Thus the sensitivity of this type of transducer is not constant but varies over the range of the transducer. The relationship between variations of capacitance with variation of distance between plates is hyperbolic and is only approximately linear over a small range of displacement. The linearity can be closely approximated by use of a piece of dielectric

material like mica having a high dielectric constant, such as, a thin piece of mica.

c) Transducers Using Change in dielectric constant between Plates

If the area (A) of and the distance (d) between the plates of a capacitor remain constant, capacitance will vary only as a function of the dielectric constant (ϵ) of the substance filling the gap between the plates. If the space between the plates of a capacitor is filled with an insulator, the capacitance of the capacitor will change compared to the situation in which there is vacuum between the plates. The change in the capacitance is caused by a change in the electric field between the plates.

The value of dielectric constant is initially set by design in the choice of dielectric material used to make the capacitor. Many factors will cause the to change, and this change in will vary for different materials. The major factors that will cause a change in are moisture, voltage, frequency, and temperature. The dielectric constant of a process material can change due to variations in temperature, moisture, humidity, material bulk density, and particle size etc. The in the basic formula is the effective dielectric constant of the total space between the electrodes. This space may consist of the dielectric material, air, and even moisture, if present. The figure shows that how in a capacitor the position of the dielectric is varied to vary the capacitance. Physical variables, such as, displacement, force or pressure can cause the movement of dielectric material in the capacitor plates, resulting in changes in the effective dielectric constant, which in turn will change the capacitance.

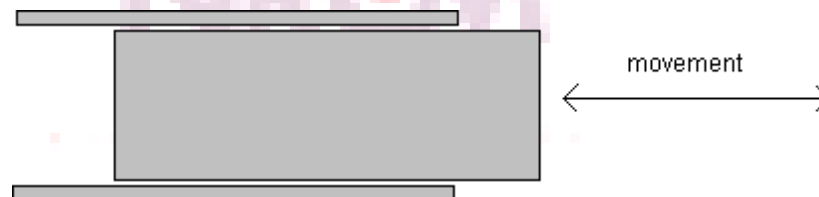

Fig. Change in capacitance due to movement of dielectric between plates

The major advantages of capacitive transducers are that they require extremely small forces to operate them and hence are very useful for use in small systems. They are extremely sensitive and require small power to operate them. Owing to their good frequency response they are very useful for dynamic studies.

The disadvantages of capacitive transducers include their non-linear behaviour on account of edge effects and the effects of stray capacitances especially when the transducers have a low value of capacitance. Therefore guard rings must be used to eliminate this effect. The metallic parts of the capacitive transducers must be insulated from each other. In order to reduce the effects of stray capacitances, the frames must be earthed.

Electrical Measurements & Instrumentation (EE3101PC)

Capacitive transducers can be used for measurement of both linear and angular displacements. The capacitive transducers are highly sensitive and can be used for measurement of extremely

small displacements down to the order of molecular dimensions, i.e., 0.1×10^{-6} mm. On the other hand, they can be used for measurement of large displacements up to about 30 m as in aeroplane altimeters. The change in area method is used for measurement of displacements ranging from 10 to 100 mm. Capacitive transducers can be used for the measurement of force and pressure. The force and pressure to be measured are first converted to displacement which causes a change of capacitance. Capacitive transducers can also be used directly as pressure transducers in all those cases where the dielectric constant of a medium changes with pressure. They can be used for measurement of humidity in gases and moisture content in soil / food products etc.

Thermocouples

Basically thermocouple consists of two different metals which are placed in contact with each other as

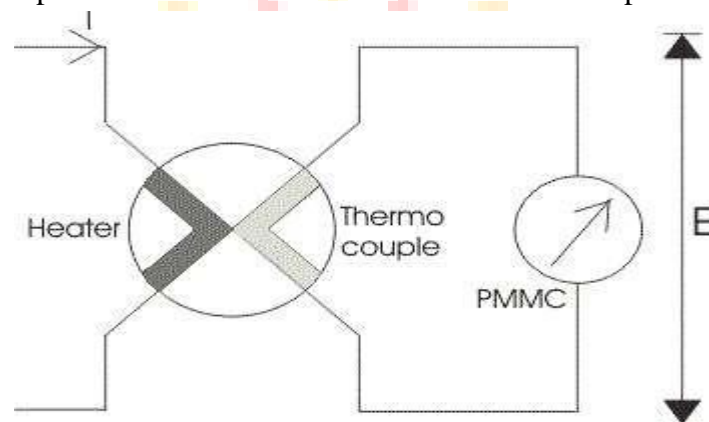

shown in the diagram.

First part is called the heater element because when the current will flow through this, a heat is produced and thus the temperature will increase at the junction. At this junction an emf is produced which is approximately proportional to the temperature difference of hot and cold junctions.

The emf produced is a DC voltage which is directly proportional to root mean square value of electric current. A permanent magnet moving coil instrument is connected with the second part to read the current passing through the heater. One question must arise in our mind that why we have used only a permanent magnet coil instrument? Answer to this question is very easy it is because PMMC instrument has greater accuracy and sensitivity towards the measurement of DC value. The **thermocouple type instruments** employ thermocouple in their construction.

Thermocouple type instruments can be used for both ac and DC applications. Also thermocouple type of instruments has greater accuracy in measuring the current and voltages at very high frequency accurately.

Now we will look how the temperature difference is mathematically related to generated emf at the junction in thermocouple type of instruments. Let us consider temperature of the heater element be T_a and the temperature of cold metal be T_b . Now it is found that the generated emf at the junction is related to temperature difference as:

$$e = a(T_a - T_b) + b(T_a - T_b)^2$$

Where a and b are constant whose values completely depends upon the type of metal we are using. The above equation represents parabolic function. The approximated value of a is from 40 to 50 micro volts or more per degree Celsius rise in temperature and value of constant b is very small and can be neglected if the air gap field of permanent magnet moving coil is uniform. Thus we can approximate the above temperature emf relation as $e = a(T_a - T_b)$, here we have assume $b = 0$. The current flowing through the heater coil produces heat as I^2R where I is the root mean square value of current, if we assume the temperature of cold junction is maintained at room temperature then the rise in the temperature of the hot junction will be equal to temperature rise at the junction. Hence we can write $(T_a - T_b)$ is directly proportional to I^2R or we can say $(T_a - T_b) = kI^2R$. Now the deflection angle x in moving coil instrument is equal to; $x = Ke$ or $x = K[a(T_a - T_b)]$ hence we can write $k.K.a.I^2R = k_1I^2$, where k_1 is some constant.

From the above equation we see that the instrument shows the square law response.

Construction of Thermocouple Type Instrument

Now let us look at the construction of Thermocouple type Instruments. Broadly speaking the thermocouple type of instruments consists of two major parts which are written below: (a)

Thermoelectric elements: The thermocouple type of instruments consists of thermo electric elements which can be of four types:

1. **Contact Type:** It has a separate heater which is shown in the diagram.

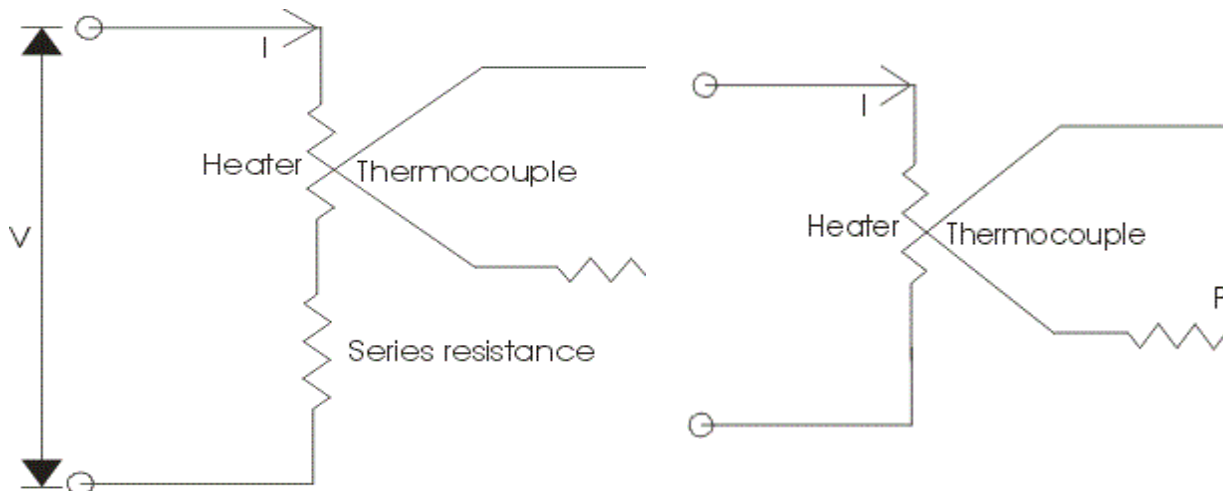

Electrical Measurements & Instrumentation (EE3101PC)

The action of thermocouple type instruments can be explained briefly as,

- At the junction the electrical energy is being converted to thermal energy in the heater element. A portion of the heat is transferred to the hot junction while most of the heat energy is dissipated away.
 - The heat energy which is transferred to hot junction is again converted to electrical due to Seebeck effect. Only a portion of electrical energy is converted into mechanical energy which is used to produce a deflecting torque. The overall efficiency of the system is low thus the instrument consumes high power. So there is a requirement of highly accurate and sensitive DC instrument.
2. **Non Contact Type:** In non contact type there is insulation between the heating element and the thermocouple i.e. there no direct contact between two. Due to this these instruments are not much sensitive as compared contact type.
 3. **Vacuum Thermo-elements:** These types of instruments are mostly employed for the measurement of electric current at very high frequency of the order of 100 Mega hertz or more as these instruments retain their accuracy even at such high frequency.
 4. **Bridge Type:** These bridges are manufactured on the ac ratings usually from 100 milli amperes to 1 amperes. In this two thermocouple are connected to form a bridge which is shown in the figure given

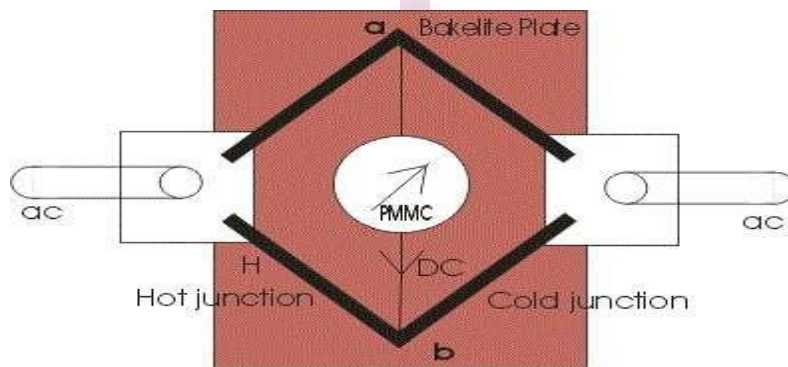

below:

5. There is no requirement of heating element, the electric current which directly passing through the thermocouple raises the temperature which is directly proportional to the I^2R losses. The bridge works on balanced condition at which there will be no current in the arm ab. The connected meter will show the potential difference between the junctions a and b.

Advantages of Thermocouple Type Instruments

Following are advantages of Thermocouple type of instruments,

1. The thermocouple type of instruments accurately indicates the root mean square value of current and voltages irrespective of the waveform. There is a wide varieties of range of thermocouple instruments are available in the market.
2. Thermocouple type of instruments give very accurate reading even at high frequency, thus these types of instruments are completely free from frequency errors.
3. The measurement of quantity under these instruments is not affected by stray magnetic fields.
4. These instruments are known for their high sensitivity.
5. Usually for measuring the low value of current bridge type of arrangement is used i.e. ranging from 0.5 Amperes to 20 Amperes while for measuring the higher value of current heater element is required to retain accuracy.

Disadvantages of Thermocouple Type Instruments

Instead of many advantages these type of instruments possess one disadvantage, The over load capacity of thermocouple type of instrument is small, even fuse is not able to the heater wire because heater wire may burn out before the fuse blows out.

Piezoelectric transducer:

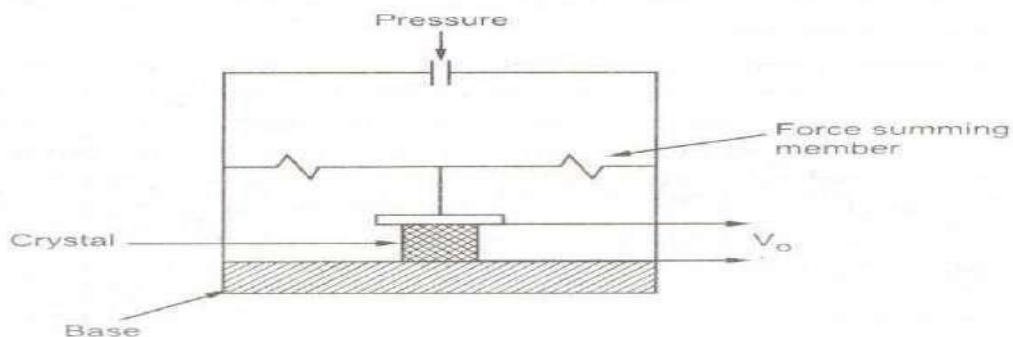

A piezoelectric quartz crystal is hexagonal prism shaped crystal, which has pyramids at both ends. This is shown in the Fig. (a). The marking of co-ordinate axes are fixed for such crystals. The axis

passing through the end points of pyramids is called optic axis or z axis. The axis passing through corners is called electrical axis or x axis while the axis passing through midpoints of opposite sides is called mechanical axis or y axis. The axes are shown in the

Digital Multimeter

Working Principle of Digital Multimeter

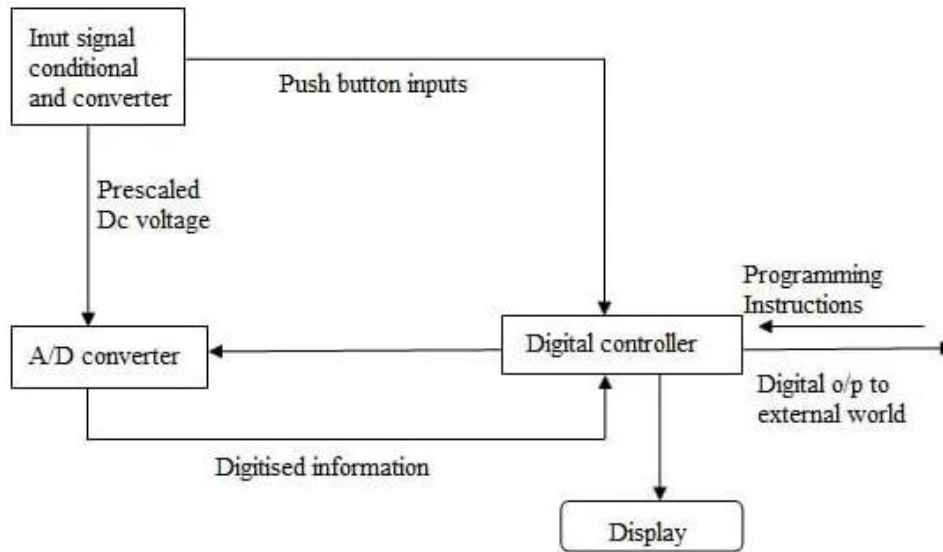

As shown in the block diagram, in a typical Digital multimeter the input signal i.e ac or dc voltage, current, resistance, temperature, or any other parameter is converted to dc voltage within the range of the ADC. The analog to digital converter then converts the pre-scaled dc voltage into its equivalent digital numbers which will be displayed on the display unit. Sometimes, a digital controller block is implemented with a microcontroller or a microprocessor to manage the flow of information within the instrument. This block will coordinate all the internal functions as well as transferring information to external devices such as printers or a personal computer. In the case of some handheld multimeter, some or all of these blocks may be implemented in a VLSI circuit while the A/D converter and display driver can be in the same IC. Digital Multimeter as Voltmeter, Ammeter and Digital Ohmmeter.

In digital multimeter, we can incorporate many types of meters like ohmmeter, ammeter, a voltmeter for the measurement of electrical parameters. Its block diagram is shown below in the figure. Let us have a look at its working and specification one by one.

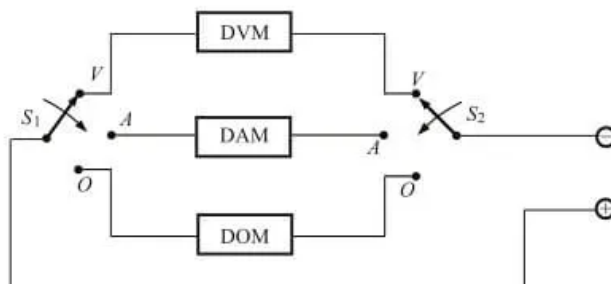

(i) Digital voltmeter (DVM):

Digital voltmeter is the basic instrument used for measurement of voltage through the use of Analog to Digital converter. The basic principle behind digital multimeters is the Analog to digital converter because without this we are not able to convert the analog output into digital form. There are several ADC available in the market, but we mainly use Flash type ADC due to its simplicity and fastest speed. Let's have a look at its basic operation.

(a) Flash AD converter:

It comprises comparators, encoders, and digital displays. Comparators are driven by a resistor divider network, the encoder converts its inputs to corresponding outputs that drive the digital display.

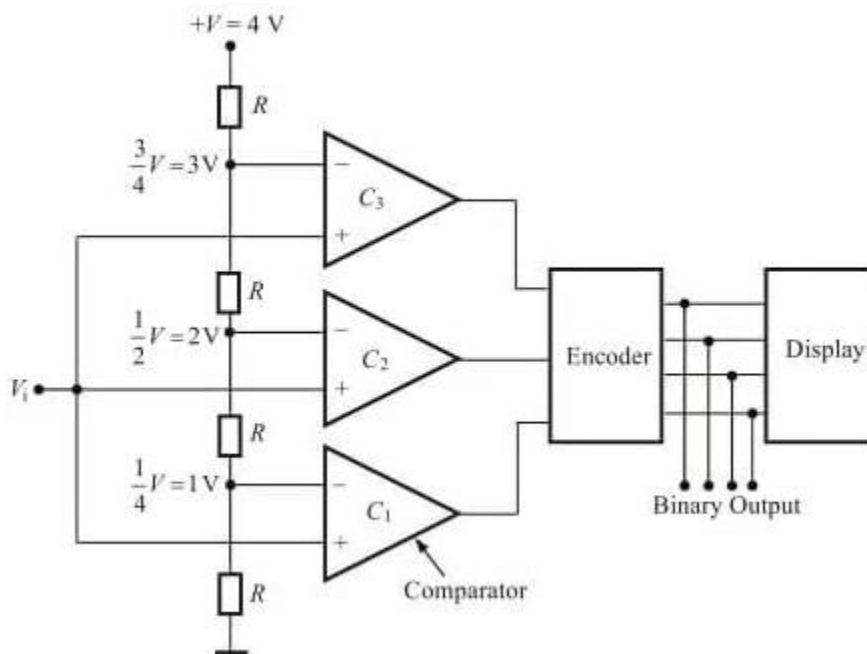

As shown above, three resistors of value R drives the comparators C_1 , C_2 , C_3 . Let the input voltage $V_i = 1V$, $+V = 4V$ and comparators i.e. C_1 , C_2 , C_3 voltages equal to $1V$, $2V$ and $3V$ respectively. If the output of the $C_1 = +1$ and $C_2 = C_3 = 0$, then we fed 001 as the input to the encoder which further converts it into 0001 . This binary output drives the seven segment display to read $1V$ on it. With the help of this method, we read the voltages of magnitude $1V$, $2V$, $3V$ and we also add more comparators for more accurate readings as per our requirement.

(ii) Digital Ammeter (DAM):

A digital ammeter uses a shunt resistor to produce a calibrated voltage proportional to the current flowing. As shown in the diagram, to read the current we must first convert the current to be measured into a voltage by using a known resistance R_K . The voltage so developed is calibrated to read the input current.

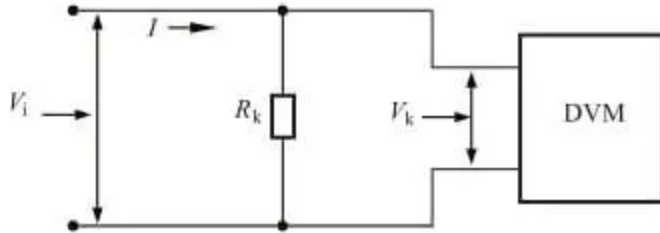

(iv) Digital ohm meter (DOM):

A digital ohmmeter is used to measure electrical resistance which obstructs the path to the flow of current. As shown in the diagram, a resistance network comprising of a known resistance R_k and unknown resistance R_u used to develop a voltage across the unknown resistance.

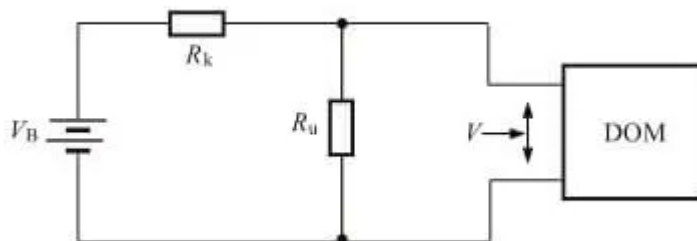

The voltage is given by: $V = V_B R_u / R_k + R_u$ where V_B = Voltage of the built-in battery
After calibrating voltage, the meter can be calibrated

A Digital Multimeter is divided into three parts: (i) Display: The LCD screen present on the upper portion of the multimeter basically displays four or more digits and also shows a negative value if necessary. A few of today's multimeters have illuminated the display for better viewing in low light situations. (ii) Selection Dial: It allows the user to set the multimeter to read different electrical parameters such as milliamps (mA) of current, voltage, resistance, capacitance, etc. You can easily turn the dial anywhere for specific parameter measurements. (iii) Ports: Two ports are available on the front of every multimeter except in some four ports are available for measuring current in mA or A. We plugged two probes into these ports which are of different colors i.e. one is of red color and the other is of black color. Different Ports in multimeter are: (a) COM: It stands for common and is almost connected to the ground or considered as a -ve connection of a circuit. We generally insert the black color probe into the COM port.

True RMS Voltmeter:

True RMS Voltmeter – Complex waveform are most accurately measured with an rms voltmeter. This instrument produces a meter indication by sensing waveform heating power, which is proportional to the square of the rms value of the voltage. This heating power can be measured by amplifying and feeding it to a [thermocouple](#), whose output voltages is then proportional to the E_{rms} .

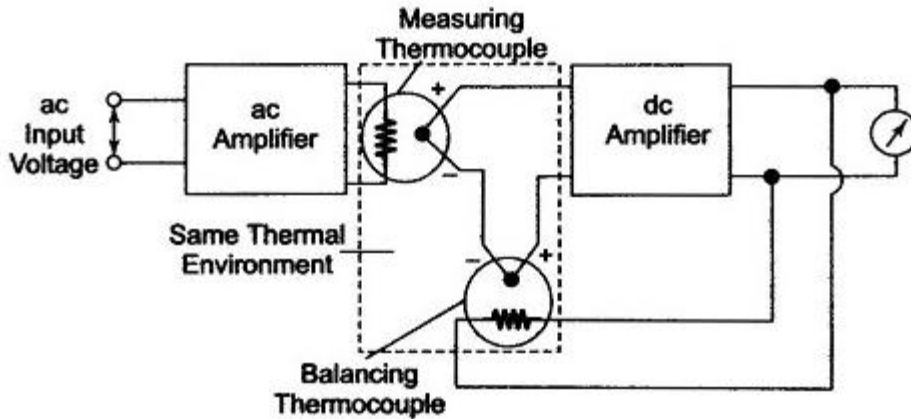

The effect of non-linear behavior of the thermocouple in the input circuit (measuring thermocouple) is cancelled by similar non-linear effects of the thermocouple in the feedback circuit (balancing thermocouple). The two couples form part of a bridge in the input circuit of a dc amplifier.

The unknown ac voltage is amplified and applied to the heating element of the measuring thermocouple. The application of heat produces an output voltage that upsets the balance of the bridge.

The dc amplifier amplifies the [unbalanced voltage](#); this voltage is fed back to the heating element of the balancing thermocouple, which heats the thermocouple, so that the bridge is balanced again, i.e. the outputs of both the thermocouples are the same. At this instant, the ac current in the input thermocouple is equal to the dc current in the heating element of the feedback thermocouple. This dc current is therefore directly proportional to the effective or rms value of the input voltage, and is indicated by the meter in the output circuit of the [dc amplifier](#). If the peak amplitude of the ac signal does not exceed the dynamic range of the ac amplifier, the true rms value of the ac signal can be measured independently.

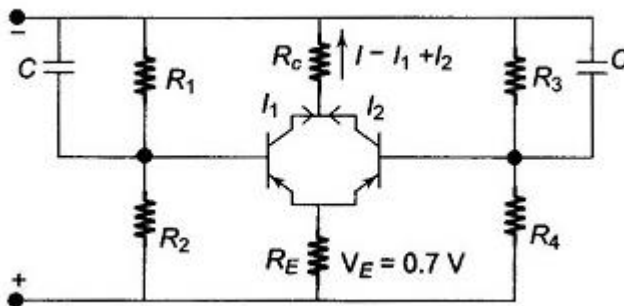

A true [rms meter](#) is always a combination of a normal mean value indicating meter and a squaring device whose output at any instant is proportional to the instantaneous squared input.

It can be shown that the ac component of the voltage developed across the common collector resistors of two transistors that are connected in parallel, and between the bases of which a small ac voltage is applied, is proportional to the square of the applied input voltage.

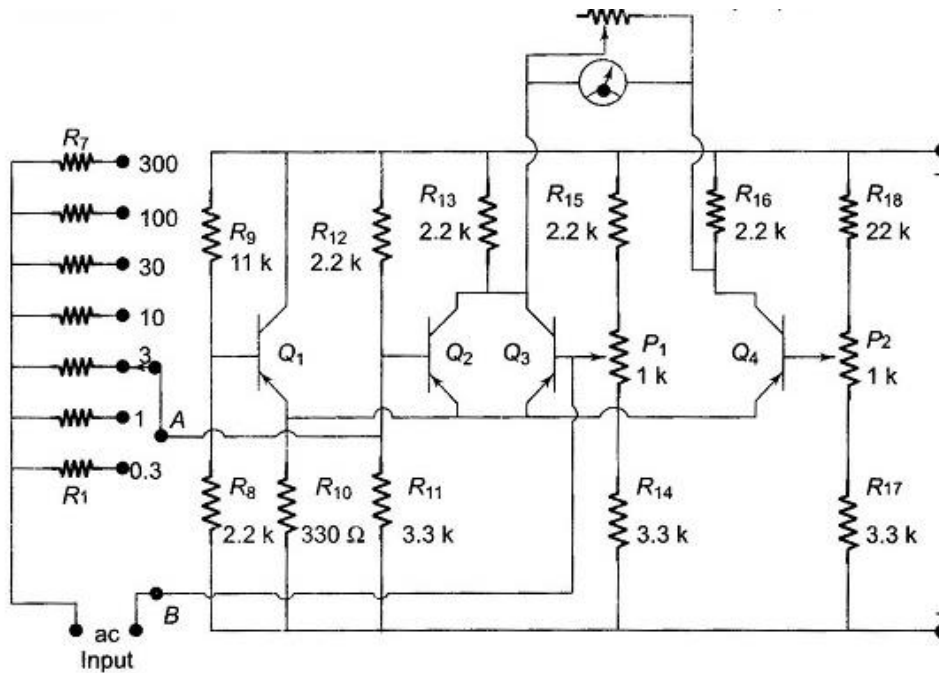

One side of the bridge consists of two parallel connected transistors Q_2 and Q_3 , and a common collector resistor R_{13} . The side of the bridge, employing P_1 for bias setting, is the basic squaring circuit. The other side of the bridge is made of transistor Q_4 (whose base is biased by means of potentiometer P_2 and collector resistance R_{16} .)

Potentiometer P_1 , base bias balance of the squaring circuit, must be adjusted for symmetrical operation of transistors Q_2 and Q_3 . To do this, the polarity of a small dc input voltage applied to terminals A and B (bases of Q_2 and Q_3) has to be reversed, and the reading of the output meter must be the same for both input polarities.

Potentiometer P_2 must be set so that for zero input signal (terminals A and B short-circuited), the bridge is balanced and the meter reads zero. The balance condition is reached if the voltage drop across the collector resistance R_{13} of $Q_2 - Q_3$, and collector resistance R_{16} of Q_4 , are equal.

Transistor Q_1 is used to improve the temperature stability of the whole circuit, which is basically obtained by the emitter resistance R_{10} . Optimum temperature compensation is obtained if the voltage drop across the emitter resistance for no signal is 0.7 V for silicon transistor.

The low current through Q_2 , Q_3 , Q_4 requires a large emitter resistance value to fulfil the condition for compensation. Therefore, another transistor, Q_1 has been added to compensate for the temperature changes of Q_2 and Q_3 .

The bias on this transistor has to be adjusted by selecting appropriate values of R_8 and R_9 so that the voltage drop across R_{10} in the balanced condition is 0.7 V for [silicon transistor](#).

Clamp Meters Working Principle

Current transformer clamp meters are equipped with rigid jaws of made of ferrite iron. The jaws are individually wrapped by coils of copper wire. Together, they form a magnetic core during measurements.

Their basic operation is like that of a transformer. It works with one primary turn, or winding, which in nearly all cases is the conductor being measured. The coils around the jaws serve as a secondary winding of the current transformer.

Current flowing through the conductor generates an alternating magnetic field that rotates around it. This field is concentrated by the clamp's iron core, inducing a flow of current in the secondary windings in the meter. The measure of the amount of magnetic field passing through the conductor (or any surface) is called magnetic flux, denoted by the Greek letter phi, Φ_m .

The signal is proportional to the ratio of the turns. A much smaller current is delivered to the meter's input due to the ratio of the number of secondary windings (those wrapped around the jaws of the clamp) vs. the number of primary windings wrapped around the core.

If, for example, the secondary has 1000 windings, then the secondary current is 1/1000 the current flowing in the primary. Thus 1 amp of current in the conductor being measured would produce 0.001 amps, or 1 milliamp, of current at the input of the meter. With this technique, much larger currents can be easily measured by increasing the number of turns in the secondary.

Internally, the current flow in the conductor can be measured either as a current—some older clamp accessories plug into the current jacks of a digital multimeter—or can be converted to a voltage. Most clamp meters now have mV output.

Hall Effect clamp meters can measure both ac and dc current up to the kilohertz (1000 Hz) range.

Like current transformer types, Hall Effect clamp meters use rigid iron jaws to concentrate the magnetic field that encircles the conductor being measured.

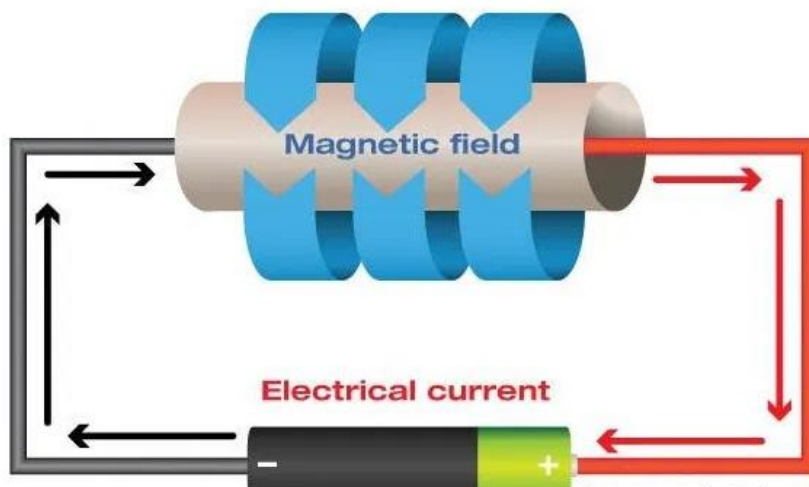

Unlike current transformer clamp meters, the jaws are not wrapped by copper wires. Instead, the magnetic field generated by the conductor is focused across one or more gaps in the core after the jaws are clamped around the conductor. A gap exists where the jaw tips of a Hall Effect clamp meter meet, creating an air pocket that the magnetic field (aka magnetic flux) must jump. This gap limits the magnetic flux so that the core cannot saturate.

In contrast, the jaws of an ac-only current transformer clamp are flush when closed. When opened, the tips of the jaws show bare metal core faces.

In that gap, covered by thin plastic molding, is a semiconductor known as a Hall Effect sensor—a transducer that varies its output voltage when responding to magnetic fields, in this case the magnetic field of the conductor or wire being measured. Its purpose is to measure magnetic flux directly. The output voltage from the sensor then amplified and scaled to represent the current flowing through the conductor that lies inside the jaws of the clamp.

As current flows through a conductor being measured, the iron core formed by the jaws of a Hall Effect clamp meter allows the magnetic field to easily pass through—more easily, in fact, than air.

When the magnetic field (flux) comes to that small air gap in the tips of the jaw, the field has to jump that gap. Because the gap is small, the field remains concentrated across the gap, and the Hall Effect sensor—which sits in the gap—produces a voltage proportional to the magnetic flux in the gap that the clamp translates into a current reading.

In Hall Effect devices, dc magnetic fields are also concentrated through the core, like a permanent magnet sticking to iron. Because of the dc magnetic field of the earth and the possibility of other magnetic fields near the measurement site, these clamps require the reading to be “zeroed” before taking a measurement to eliminate offsets.

Digital Storage Oscilloscope : Working & Its Applications

Definition: The digital storage oscilloscope is an instrument which gives the storage of a digital waveform or the digital copy of the waveform. It allows us to store the signal or the waveform in the digital format, and in the digital memory also it allows us to do the digital signal processing techniques over that signal. The maximum frequency measured on the digital signal oscilloscope depends upon two things they are: sampling rate of the scope and the nature of the converter. The traces in DSO are bright, highly defined, and displayed within seconds.

Block Diagram of Digital Storage Oscilloscope

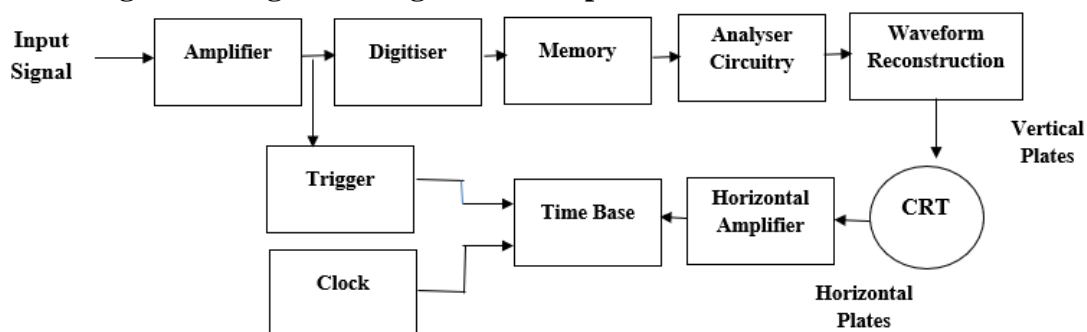

Electrical Measurements & Instrumentation (EE3101PC)

The block diagram of the digital storage oscilloscope consists of an amplifier, digitizer, memory, analyzer circuitry. Waveform reconstruction, vertical plates, horizontal plates, cathode ray tube (CRT), horizontal amplifier, time base circuitry, trigger, and clock. The block diagram of the digital storage oscilloscope is shown in the below figure.

As seen in the above figure, at first digital storage oscilloscope digitizes the analog input signal, then the analog input signal is amplified by amplifier if it has any weak signal. After amplification, the signal is digitized by the digitizer and that digitized signal stores in memory. The analyzer circuit process the digital signal after that the waveform is reconstructed (again the digital signal is converted into an analog form) and then that signal is applied to vertical plates of the cathode ray tube (CRT).

The cathode ray tube has two inputs they are vertical input and horizontal input. The vertical input signal is the 'Y' axis and the horizontal input signal is the 'X' axis. The time base circuit is triggered by the trigger and clock input signal, so it is going to generate the time base signal which is a ramp signal. Then the ramp signal is amplified by the horizontal amplifier, and this horizontal amplifier will provide input to the horizontal plate. On the CRT screen, we will get the waveform of the input signal versus time.

The digitizing occurs by taking a sample of the input waveform at periodic intervals. At the periodic time interval means, when half of the time cycle is completed then we are taking the samples of the signal. The process of digitizing or sampling should follow the sampling theorem. The [sampling theorem](#) says that the rate at which the samples are taken should be greater than twice the highest frequency present in the input signal. When the analog signal is not properly converted into digital then there occurs an aliasing effect.

When the analog signal is properly converted into digital then the resolution of the A/D converter will be decreased. When the input signals stored in analog store registers can be read out at a much slower rate by the A/D converter, then the digital output of the A/D converter stored in the digital store, and it allows operation up to 100 mega samples per second. This is the working principle of a digital storage oscilloscope.

DSO Operation Modes

The digital storage oscilloscope works in three modes of operations they are roll mode, store mode, and hold or save mode.

Roll Mode: In roll mode, very fast varying signals are displayed on the display screen.

Store Mode: In the store mode the signals stores in memory.

Hold or Save Mode: In hold or save mode, some part of the signal will hold for some time and then they will be stored in memory.

These are the three modes of digital storage oscilloscope operation.

Waveform Reconstruction

There are two types of waveform reconstructions they are linear interpolation and sinusoidal interpolation.

Linear Interpolation: In linear interpolation, the dots are joined by a straight line.

Sinusoidal Interpolation: In sinusoidal interpolation, the dots are joined by a sine wave.

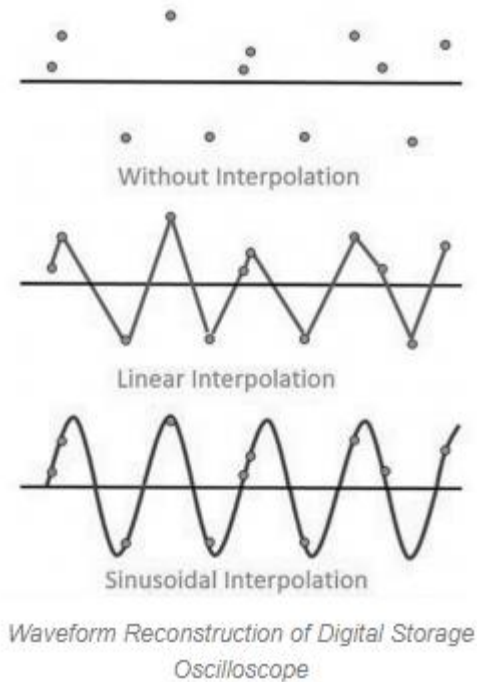

Applications

The applications of the DSO are

- It checks faulty components in circuits
- Used in the medical field
- Used to measure [capacitor](#), inductance, time interval between signals, frequency and time period
- Used to observe transistors and diodes V-I characteristics
- Used to analyze TV waveforms
- Used in video and audio recording equipment's
- Used in designing
- Used in the research field
- For comparison purpose, it displays 3D figure or multiple waveforms
- It is widely used an oscilloscope

Advantages

The advantages of the DSO are

- Portable
- Have the highest bandwidth
- The user interface is simple
- Speed is high

Disadvantages

The disadvantages of the DSO are

- Complex
- High cost